

MODEL: 8095-902-290

SPECIFICATIONS:

MODEL NUMBER: 8095-902-290

PUMP DESIGN: Positive Displacement 3 Chamber Diaphragm Pump

CAM: 2.5 Degree

MOTOR: Permanent Magnet, P/N 11-160-10, Thermally Protected

VOLTAGE: 230 VAC Nominal

PRESSURE SWITCH: None

LIQUID TEMPERATURE: 180 Degrees Fahrenheit (82 Degrees Centigrade) Max.

PRIME: Self-Priming Up To 11 Ft. Vertical,
Max. Inlet Pressure 30 PSI (2.1 Bar)

PORTS: 3/8"-18 NPT Female

MATERIAL OF CONSTRUCTION:

PLASTICS- Nylon

VALVES- EPDM

DIAPHRAGM- Santoprene

FASTENERS- Zinc Plated Steel

NET WEIGHT: 4.5 Lbs (2.0 Kg)

DUTY CYCLE: Intermittent (See Temperature Rise Chart)

APPROVALS: VDE Approved, NSF Listed

TYPICAL APPLICATIONS: Carbonator

BYPASS: 100 PSI Spring

DIMENSIONS:

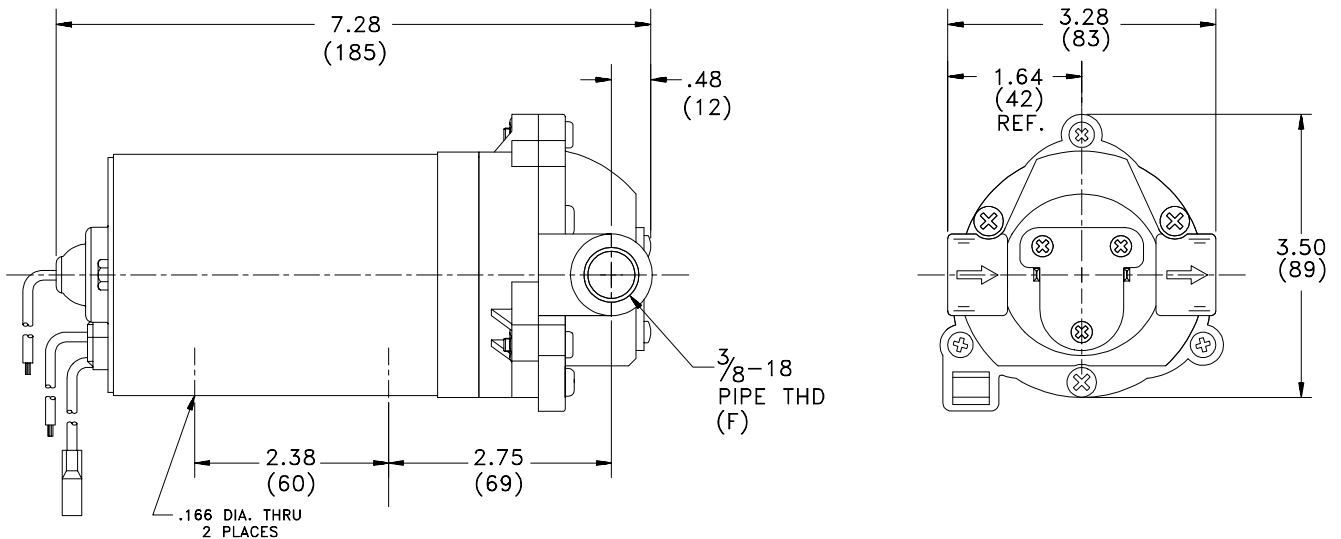

TEMPERATURE RISE

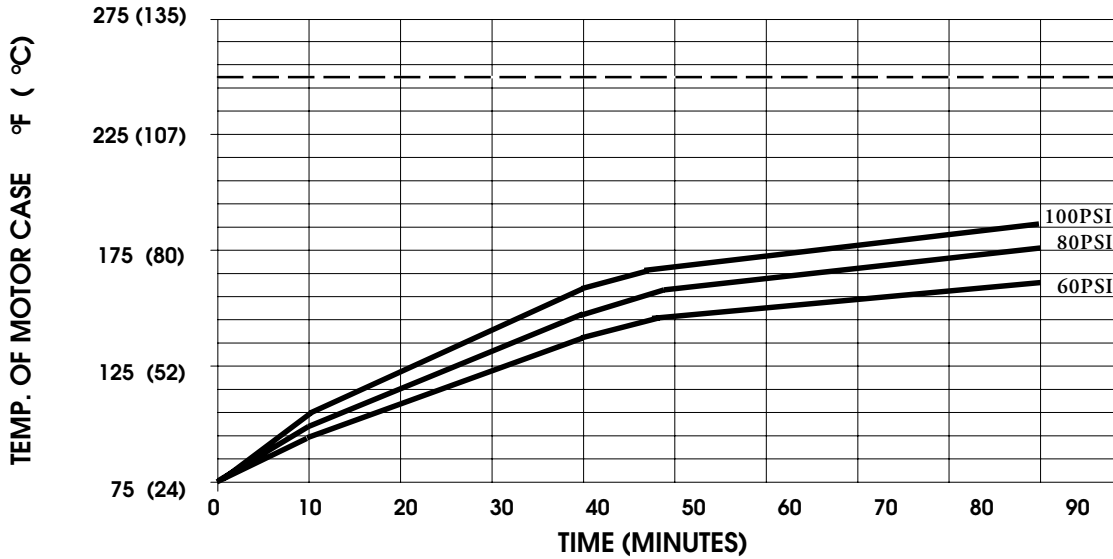

THIS GRAPH IS FOR USE AS A DESIGN GUIDE. IT IS BASED ON RUNNING CONTINUOUSLY WITH AN AMBIENT TEMPERATURE OF 75 F IN STILL AIR. THE THERMAL BREAKER WILL OPEN WHEN THE CASE TEMPERATURE REACHES 250 F.

[----- TRIP POINT OF THERMAL PROTECTOR]

TYPICAL PERFORMANCE

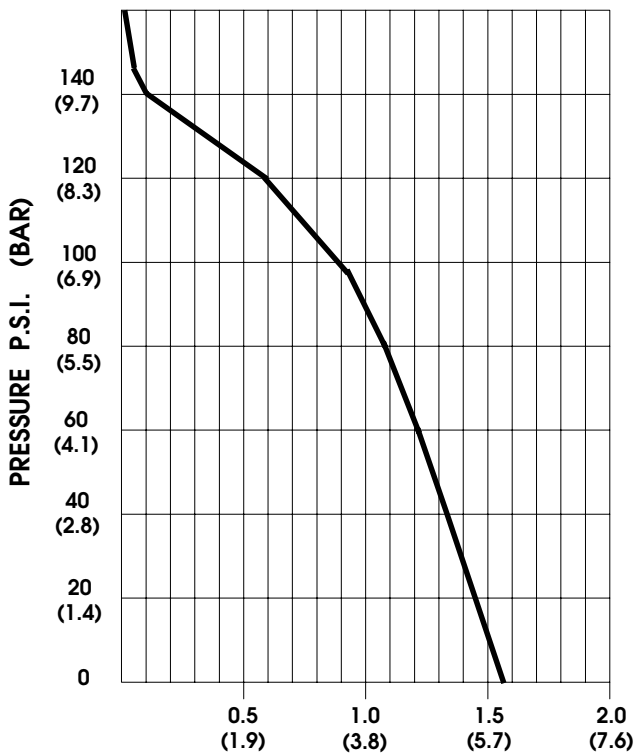

PRESSURE (PSI)	FLOW (GPM/LIT)	RPM MIN/MAX	CURRENT (AMPS)	VOLTAGE (VOLTS)
OPEN	1.57/5.9	2545/2580	0.19	230 VAC
10	1.52/5.7	2465/2560	0.21	"
20	1.47/5.5	2415/2475	0.23	"
30	1.39/5.3	2335/2395	0.26	"
40	1.32/5.0	2260/2315	0.29	"
50	1.26/4.8	2190/2250	0.32	"
60	1.21/4.6	2115/2175	0.34	"
70	1.15/4.3	2050/2110	0.37	"
80	1.09/4.1	1990/2045	0.39	"
100	0.94/3.6	1865/1940	0.44	"
120	0.60/2.3	1740/1835	0.49	"

FLOW - GALLONS PER MINUTE (LITERS PER MINUTE)

-SPECIFICATIONS SUBJECT TO CHANGE WITHOUT NOTICE.

-ALL DATA BASED ON TESTING WITH WATER AT AMBIENT TEMPERATURE.