

### SPECIFICATIONS:

**MODEL NUMBER:** 8090-987-850

**PUMP DESIGN:** Positive Displacement 3 Chamber Diaphragm Pump

**CAM:** 3.0 Degree Solid

**MOTOR:** Permanent Magnet, P/N 11-275-00, RFI Ball Bearing

**VOLTAGE:** 115 VAC Nominal

**PRESSURE SWITCH:** None

**LIQUID TEMPERATURE:** 170 Degrees Fahrenheit (76 Degrees Centigrade) Max.

**PRIME:** Self-Priming Up To 8.0 Ft. Vertical,  
Max. Inlet Pressure 30 PSI (2.1 Bar)

**PORTS:** 3/8"-18 NPT Female

**MATERIAL OF CONSTRUCTION:**

**PLASTICS-** Poly

**VALVES-** Silicon

**DIAPHRAGM-** Santoprene

**FASTENERS-** Zinc Plated Steel

**NET WEIGHT:** 3.85 Lbs (1.75 Kg)

**DUTY CYCLE:** Continuous (See Temperature Rise Chart)

**TYPICAL APPLICATIONS:** Chemical/Transfer

**BYPASS:** 35 PSI

### DIMENSIONS:

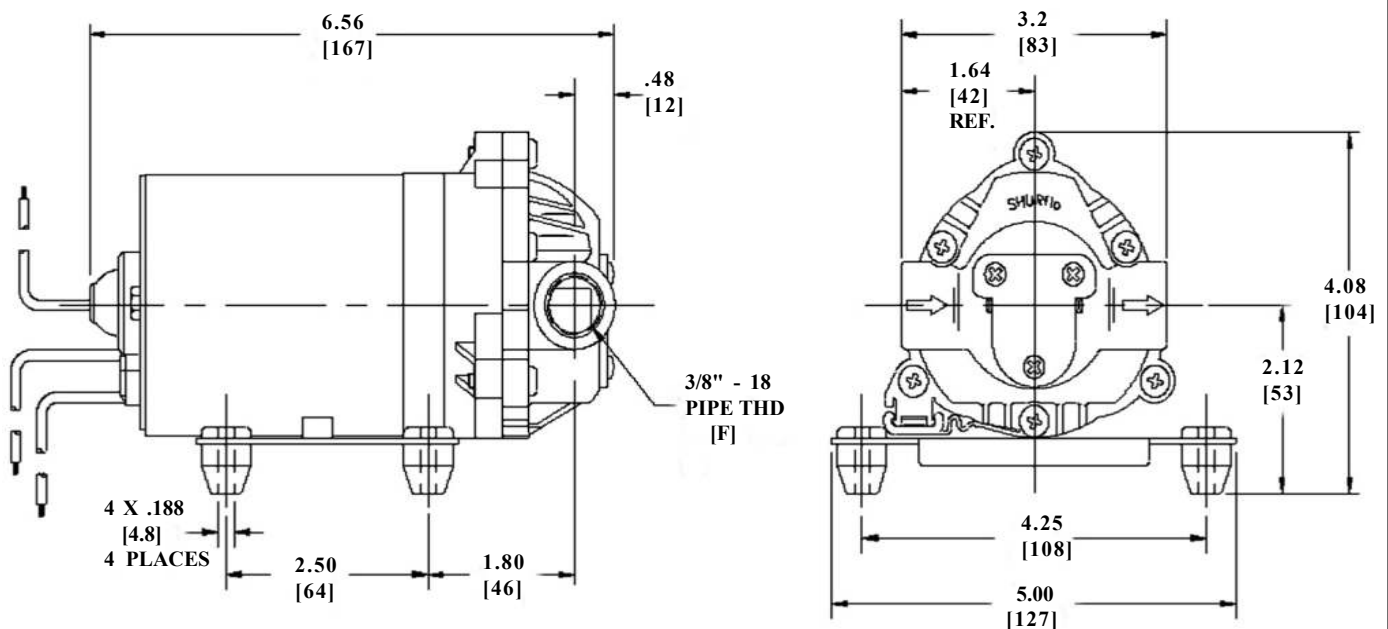

**TEMPERATURE RISE**

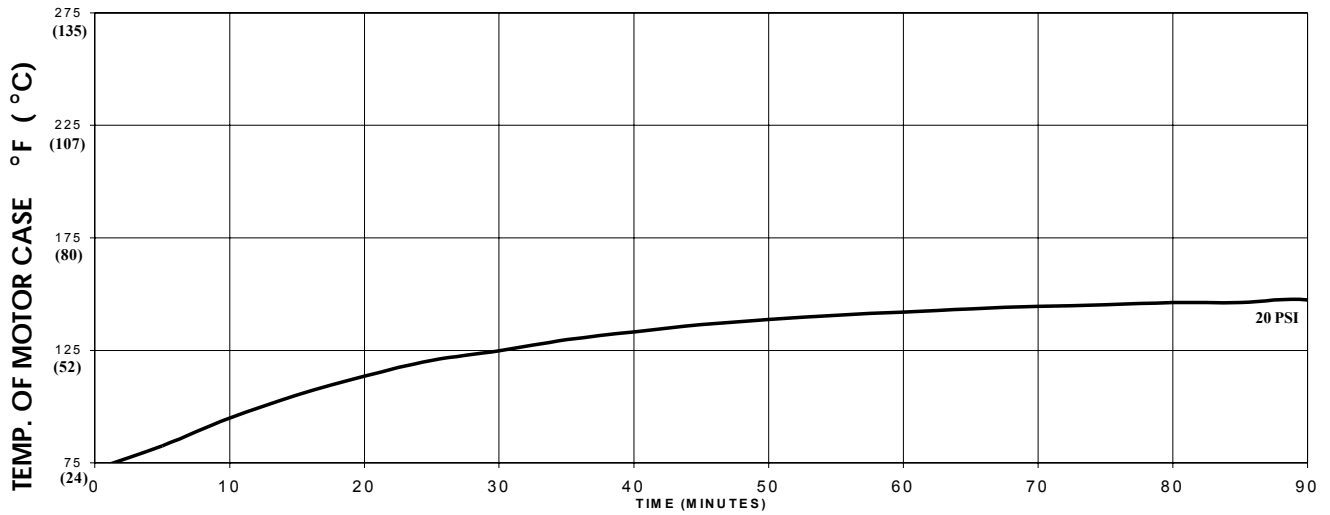

THIS GRAPH IS FOR USE AS A DESIGN GUIDE. IT IS BASED ON RUNNING CONTINUOUSLY WITH AN AMBIENT TEMPERATURE OF 75°F IN STILL AIR. THE THERMAL BREAKER WILL OPEN WHEN THE CASE TEMPERATURE REACHES 250°F.

[----- TRIP POINT OF THERMAL PROTECTOR]

**TYPICAL PERFORMANCE**

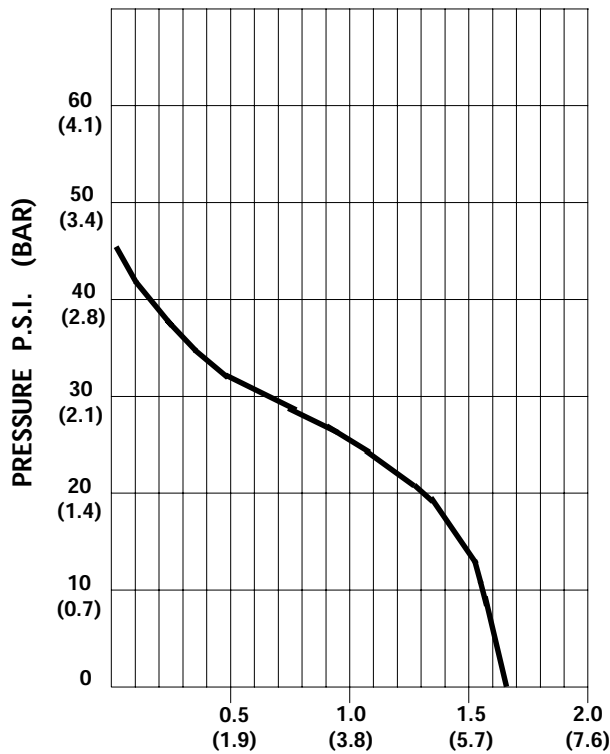

PRESSURE (PSI)	FLOW (GPM/LIT)	RPM MIN/MAX	CURRENT (AMPS)	VOLTAGE (VOLTS)
OPEN	1.60/6.1	2230/2280	0.35	115 VAC
10	1.50/5.7	2100/2210	0.41	"
20	1.38/5.2	1900/1990	0.48	"
30	0.68/2.6	1880/1900	0.53	"

FLOW - GALLONS PER MINUTE (LITERS PER MINUTE)

*-SPECIFICATIONS SUBJECT TO CHANGE WITHOUT NOTICE.*

*-ALL DATA BASED ON TESTING WITH WATER AT AMBIENT TEMPERATURE.*