

SPECIFICATIONS:

MODEL NUMBER: 8090-901-248

PUMP DESIGN: Positive Displacement 3 Chamber Diaphragm Pump

CHECK VALVE: (2-Way Op.) Prevents Reverse Flow & 6 Ft. Head Forward Flow

CAM: 2.0 Degree

MOTOR: Permanent Magnet, P/N 11-160-10, Thermally Protected

VOLTAGE: 230 VAC Nominal

PRESSURE SWITCH: Adjustable Shut-Off (Range 80-100 PSI)

Factory Set @ 100 PSI, Turn On 85 PSI \pm 5 PSI

LIQUID TEMPERATURE: 180 Degrees Fahrenheit (82 Degrees Centigrade) Max.

PRIME: Self-Priming Up To 5 Ft. Vertical,
Max. Inlet Pressure 30 PSI (2.1 Bar)

PORTS: 3/8"-18 NPT Female

MATERIAL OF CONSTRUCTION:

PLASTICS- Nylon

VALVES- EPDM

DIAPHRAGM- Santoprene

FASTENERS- Zinc Plated Steel

NET WEIGHT: 4.8 Lbs (2.18 Kg)

DUTY CYCLE: Intermittent (See Temperature Rise Chart)

TYPICAL APPLICATIONS: Soil Extraction

APPROVALS: VDE Approved

DIMENSIONS:

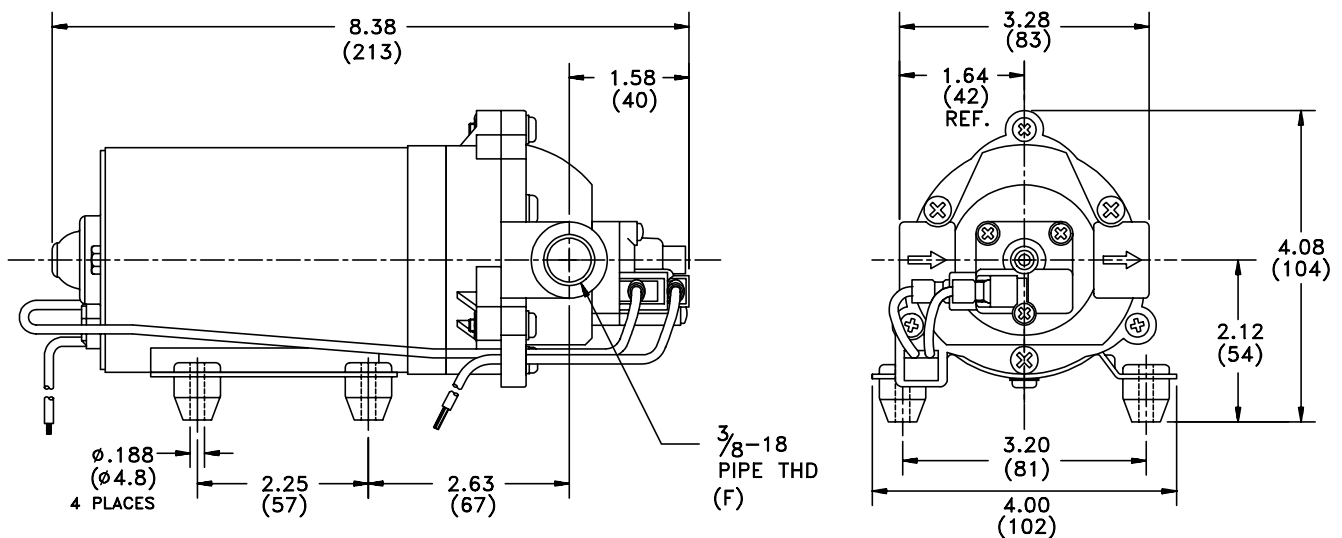

TEMPERATURE RISE

MODEL: 8090-901-248

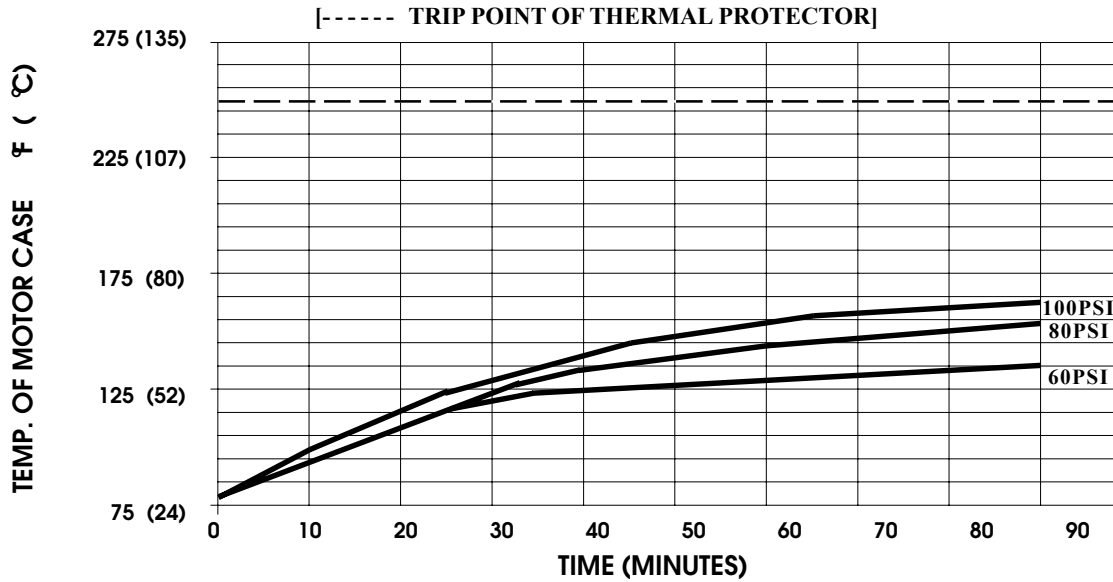

THIS GRAPH IS FOR USE AS A DESIGN GUIDE. IT IS BASED ON RUNNING CONTINUOUSLY WITH AN AMBIENT TEMPERATURE OF 80° F IN STILL AIR. THE THERMAL BREAKER WILL OPEN WHEN THE CASE TEMPERATURE REACHES 250° F.

TYPICAL PERFORMANCE

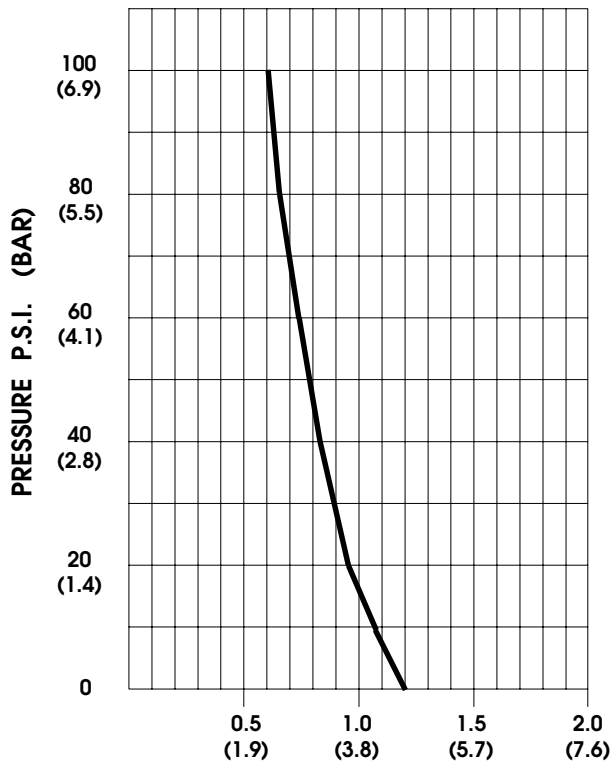

PRESSURE (PSI)	FLOW (GPM/LIT)	RPM MIN/MAX	CURRENT (AMPS)	VOLTAGE (VOLTS)
OPEN	1.20/4.5	2545/2570	0.16	230VAC
10	1.00/3.8	2505/2530	0.18	"
20	0.93/3.5	2440/2455	0.20	"
30	0.87/3.3	2370/2390	0.22	"
40	0.83/3.1	2315/2330	0.24	"
50	0.78/2.9	2260/2270	0.25	"
60	0.74/2.8	2220/2230	0.26	"
70	0.70/2.6	2180/2190	0.27	"
80	0.66/2.5	2145/2155	0.28	"
90	0.63/2.4	2105/2110	0.30	"
100	0.60/2.3	2045/2070	0.31	"

FLOW - GALLONS PER MINUTE (LITERS PER MINUTE)

-SPECIFICATIONS SUBJECT TO CHANGE WITHOUT NOTICE.

-ALL DATA BASED ON TESTING WITH WATER AT AMBIENT TEMPERATURE.