

SPECIFICATIONS:

- MODEL NUMBER:** 8090-801-278
- PUMP DESIGN:** Positive Displacement 3 Chamber Diaphragm Pump
- CHECK VALVE:** (1-Way Operation) Prevents Reverse Flow
- CAM:** 2.0 Degree
- MOTOR:** Permanent Magnet, P/N 11-160-10, Thermally Protected
- VOLTAGE:** 230 VAC Nominal
- PRESSURE SWITCH:** Adjustable Shut-Off (Range 80-100 PSI)
 Factory Set @ 100 PSI, Turn On 85 PSI ± 5 PSI
- LIQUID TEMPERATURE:** 180 Degrees Fahrenheit (82 Degrees Centigrade) Max.
- PRIME:** Self-Priming Up To 7 Ft. Vertical,
 Max. Inlet Pressure 30 PSI (2.1 Bar)
- PORTS:** 3/8"-18 NPT Female
- MATERIAL OF CONSTRUCTION:**
 - PLASTICS-** Nylon
 - VALVES-** Viton
 - DIAPHRAGM-** Santoprene
 - FASTENERS-** Zinc Plated Steel
- NET WEIGHT:** 4.8 Lbs (2.18 Kg)
- DUTY CYCLE:** Intermittent (See Temperature Rise Chart)
- TYPICAL APPLICATIONS:** Soil Extraction
- APPROVALS:** VDE Approved

DIMENSIONS:

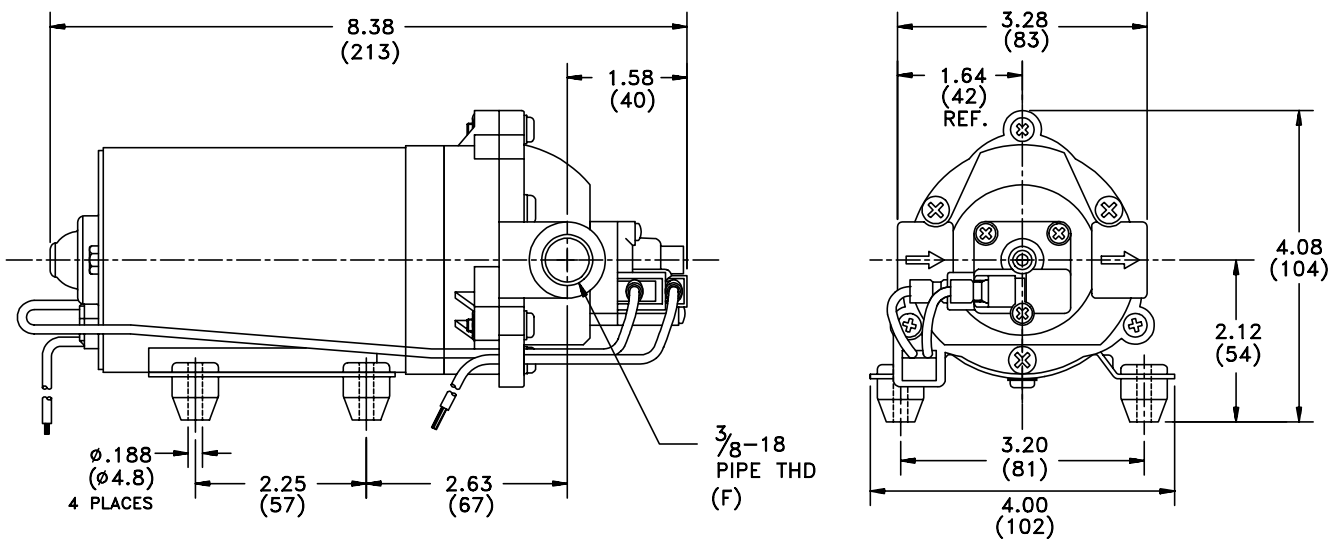

TEMPERATURE RISE

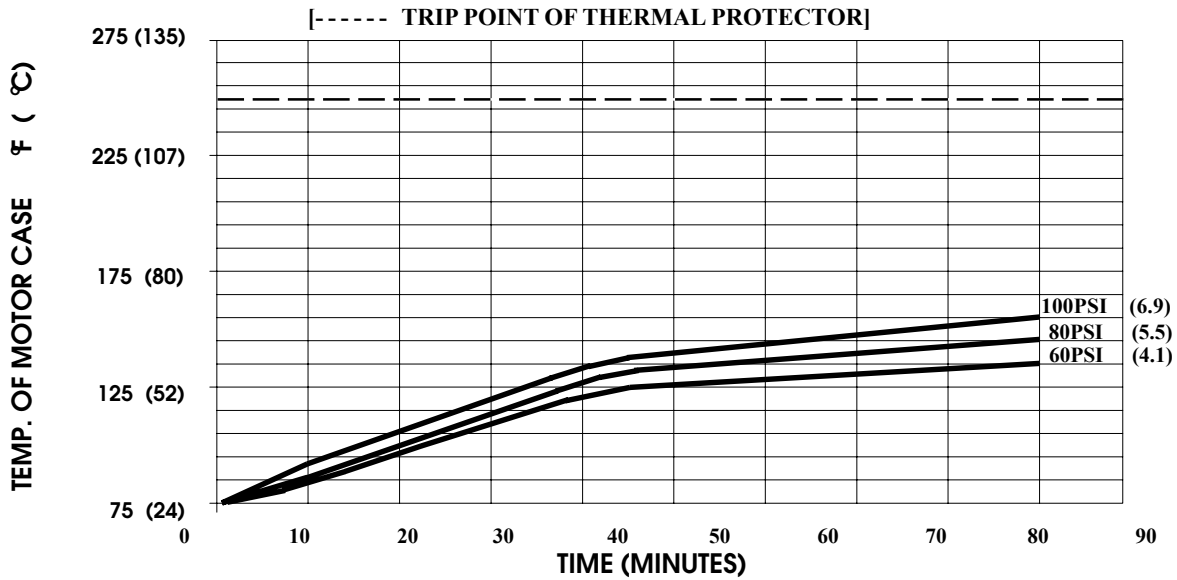

THIS GRAPH IS FOR USE AS A DESIGN GUIDE. IT IS BASED ON RUNNING CONTINUOUSLY WITH AN AMBIENT TEMPERATURE OF 70° F IN STILL AIR. THE THERMAL BREAKER WILL OPEN WHEN THE CASE TEMPERATURE REACHES 250° F.

*-SPECIFICATIONS SUBJECT TO CHANGE WITHOUT NOTICE.
-ALL DATA BASED ON TESTING WITH WATER AT AMBIENT TEMPERATURE.*

TYPICAL PERFORMANCE

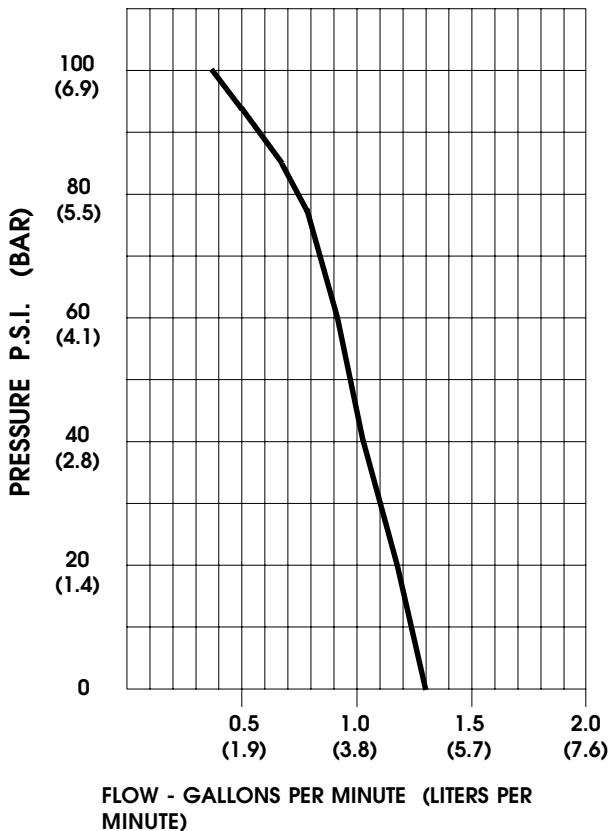

PRESSURE (PSI)	FLOW (GPM/LIT)	RPM MIN/MAX	CURRENT (AMPS)	VOLTAGE (VOLTS)
OPEN	1.31/5.0	2575/2645	0.16	230VAC
10	1.26/4.8	2495/2550	0.18	"
20	1.18/4.5	2435/2485	0.20	"
30	1.09/4.1	2360/2420	0.23	"
40	1.02/3.9	2305/2360	0.24	"
50	0.97/3.7	2255/2315	0.27	"
60	0.92/3.5	2205/2280	0.29	"
70	0.86/3.2	2160/2240	0.31	"
80	0.77/2.9	2115/2180	0.32	"
90	0.64/2.4	2065/2130	0.35	"
100	0.38/1.4	2025/2100	0.38	"