

**SPECIFICATIONS:**

- MODEL NUMBER:** 8090-512-256
- PUMP DESIGN:** Positive Displacement 3 Chamber Diaphragm Pump
- CHECK VALVE:** (1-Way Operation) Prevents Reverse Flow
- CAM:** 2.5 Degree
- MOTOR:** Permanent Magnet, P/N 11-160-00, Thermally Protected
- VOLTAGE:** 230 VAC Nominal
- PRESSURE SWITCH:** Adjustable Shut-Off (Range 40-60 PSI)  
 Factory Set @ 60 PSI, Turn On 45 PSI ± 5 PSI
- LIQUID TEMPERATURE:** 170 Degrees Fahrenheit (77 Degrees Centigrade) Max.
- PRIME:** Self-Priming Up To 7 Ft. Vertical,  
 Max. Inlet Pressure 30 PSI (2.1 Bar)
- PORTS:** 3/8"-18 NPT Female
- MATERIAL OF CONSTRUCTION:**
  - PLASTICS-** Polypropylene
  - VALVES-** Viton
  - DIAPHRAGM-** Santoprene
  - FASTENERS-** Zinc Plated Steel
- NET WEIGHT:** 3.85 Lbs (1.75 Kg)
- DUTY CYCLE:** Intermittent (See Temperature Rise Chart)
- TYPICAL APPLICATIONS:** Soil Extraction
- APPROVALS:** VDE Approved

**DIMENSIONS:**

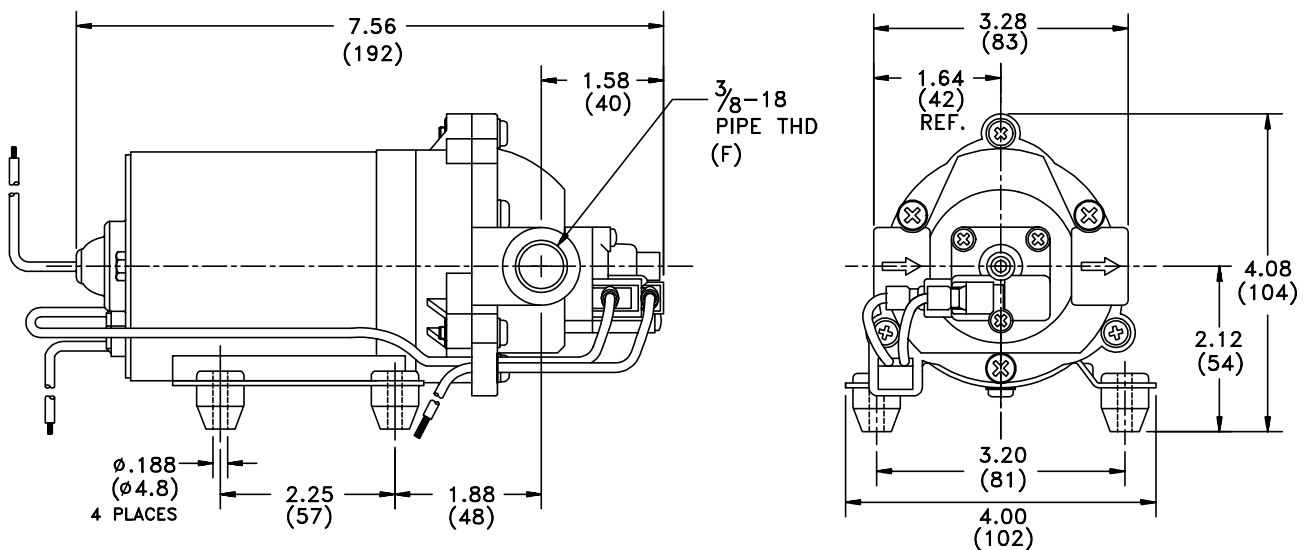

**TEMPERATURE RISE**

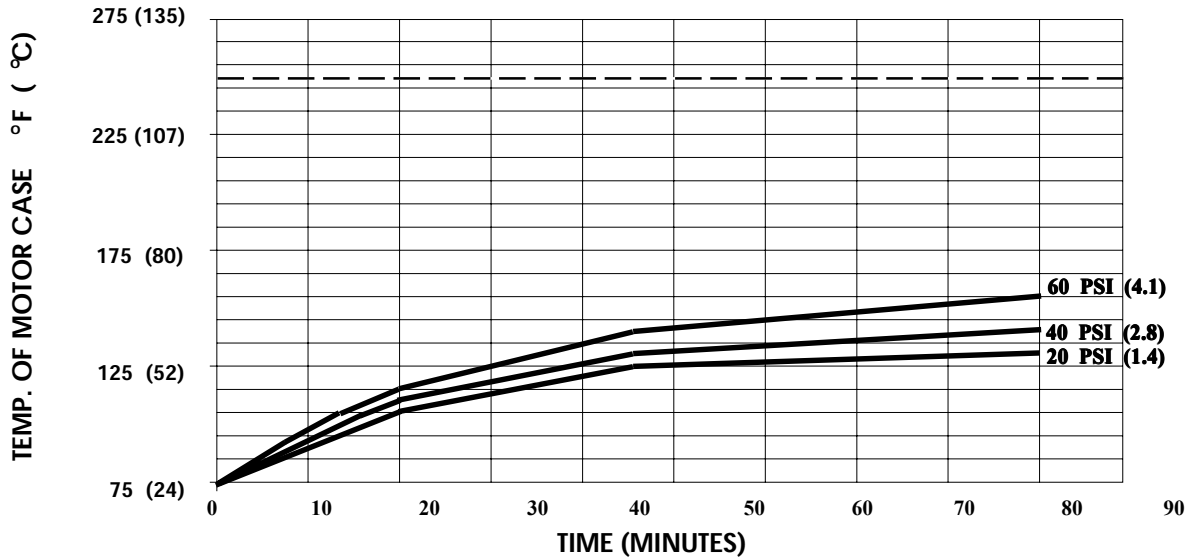

THIS GRAPH IS FOR USE AS A DESIGN GUIDE. IT IS BASED ON RUNNING CONTINUOUSLY WITH AN AMBIENT TEMPERATURE OF 70° F IN STILL AIR. THE THERMAL BREAKER WILL OPEN WHEN THE CASE TEMPERATURE REACHES 250° F.

[----- TRIP POINT OF THERMAL PROTECTOR]

**TYPICAL PERFORMANCE**

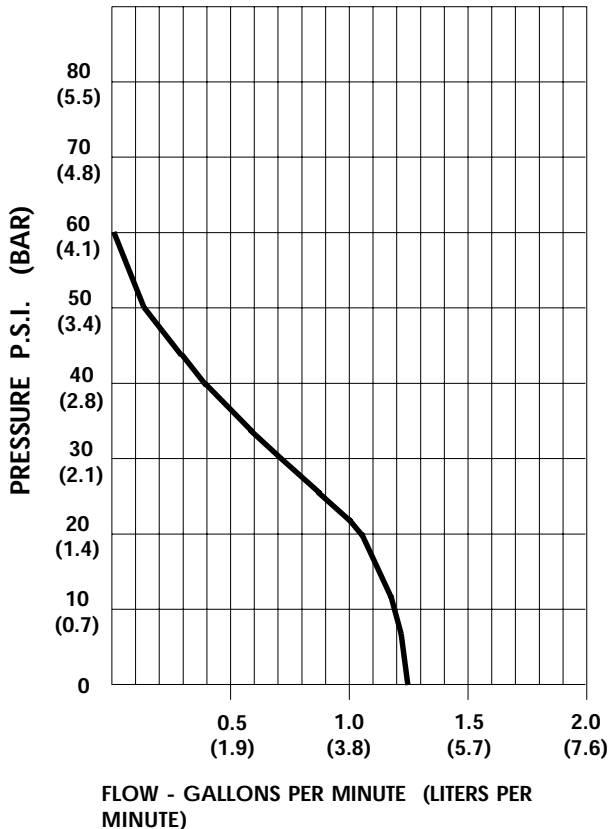

PRESSURE (PSI)	FLOW (GPM/LIT)	RPM MIN/MAX	CURRENT (AMPS)	VOLTAGE (VOLTS)
OPEN	1.25/4.7	2285/2310	.16	230 VAC
10	1.18/4.5	2180/2195	.18	"
20	1.05/4.0	2065/2075	.20	"
30	0.63/2.4	1960/1975	.23	"
40	0.42/1.6	1855/1865	.25	"
50	0.13/0.5	1765/1780	.28	"
60	0.01/.04	1715/1760	.29	"

*-SPECIFICATIONS SUBJECT TO CHANGE WITHOUT NOTICE.*

*-ALL DATA BASED ON TESTING WITH WATER AT AMBIENT TEMPERATURE.*