

General Purpose Pumps

MARINE PRODUCT DATA SHEET

OEM: N/A
AFTERMARKET: 8050-305-526



Incorporating SHURflo's advance motor technology that includes thermal overload protection, these pumps are self-priming, easy to install and are extremely versatile-perfect for a variety of uses including winterizing, Oil changing and liquid transfer.

TYPICAL APPLICATIONS

Oil change, winterizing, automatic transmission fluids, anti-freeze solutions, low viscosity gear and liquid transfer. Other uses may include 12 VDC pressurized water systems, For other applications contact SHURflo.

PUMP

Type: 3 Chamber Diaphragm
Ports: 3/8" NPT-Female
Liquid: 130 °F [54 °C] Max
Prime: 6 feet [1.82 M]
Inlet PSI: 30 PSI [2.1 Bar] Max
Run Dry: Yes

ELECTRICAL

Motor: 12VDC Permanent Magnet, Continuous Duty
Protection: Thermal Overload
Leads: 16 AWG, 16" [40 cm] Red +, 13" [33 cm] Black -
Fuse: 7.5 Amp Recommended
Control: 35 PSI Internal By-Pass

MATERIALS

Housing: Polypropylene
Valves: Buna
Diaphragm: Geolast 87 Shore
Hardware: Stainless Steel

APPROVALS

c-UL Marine, Ignition Protected, ISO 8846

WARRANTY

1 Year Limited Warranty
See SB-1041 & SB-1050 For Full Warranty Details

SHIPPING

Net Weight (Boxed): 28 Lb [12.7 Kg] each
Carton Weight: 6 each, Lb [Kg]
Carton Size: 24"L x 18"W x 6"H
[61 cm x 46 cm x 15 cm]

RELATED DOCUMENTS

Catalog: MS-030-140
Installation Manual: 911-714
Maintenance: 911-314
Applications Spec Guide: MS-020-005
Warranty: SB-1050

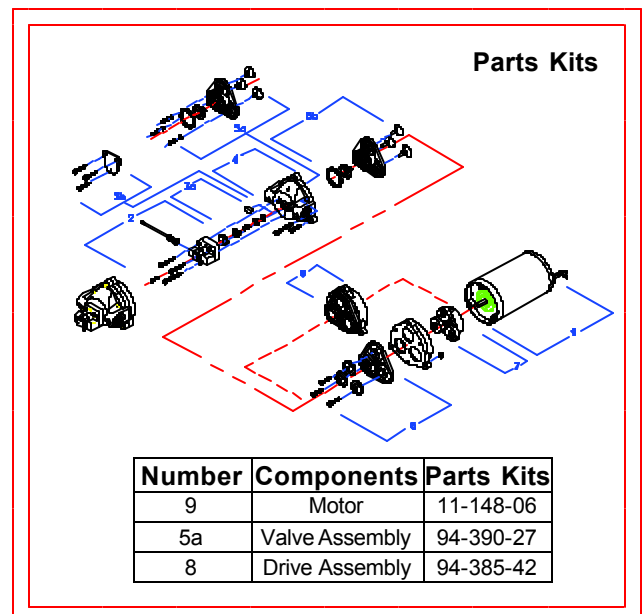

PERFORMANCE @ 12V DC WITH WATER

PRESSURE		FLOW		CURRENT
BAR	PSI	GPM	LPM	AMPS
0.0	0	1.55	5.86	2.2
0.7	10	1.45	5.48	2.8
1.4	20	1.36	5.14	3.5
2.1	30	1.10	4.16	4.1
2.8	40	0.15	0.56	4.4

TYPICAL MOTOR SHELL T-RISE @ 40 PSI, 12V

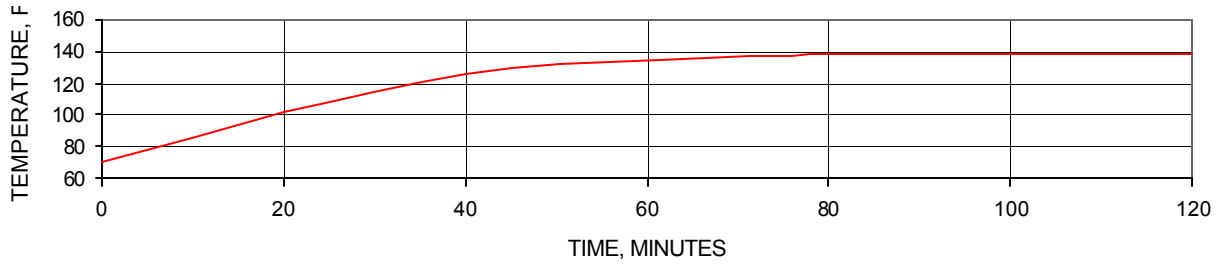

DIMENSIONS [mm]

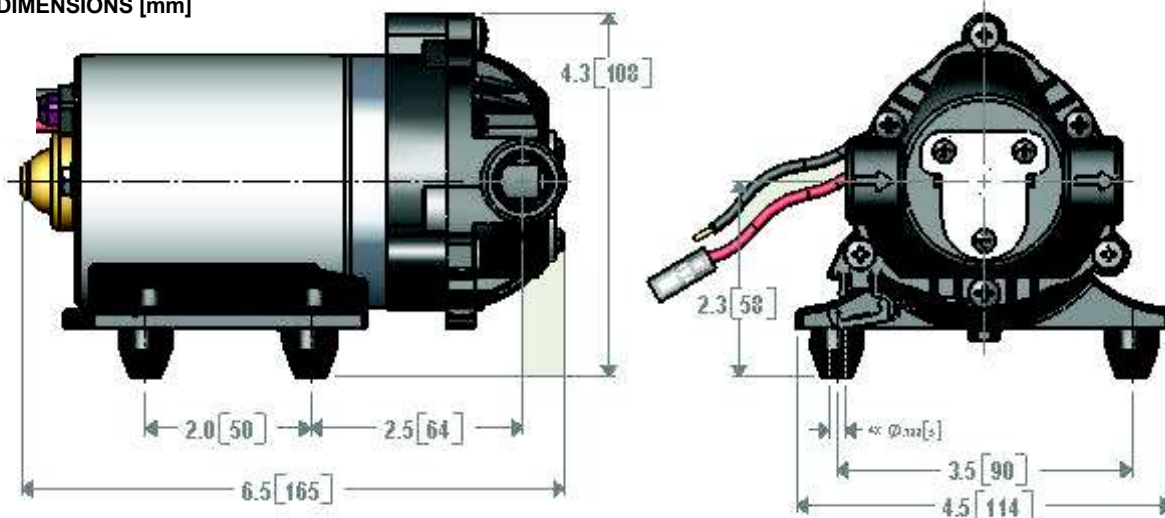

*ISO Registered Facility *SHURflo reserves the right to update specifications, prices, or make substitutions.*

SHURflo *
 5900A Katella Ave.
 Cypress, Ca. 90630
 (800) 854-3218 (562) 795-5200
 FAX (562) 795-7554
 Shipping/UPS: 5900C Katella Ave.
 Cypress, Ca. 90630

SHURflo East
 52748 Park Six Court
 Elkhart, IN 46514-5427
 (800) 762-809 (574) 262-0478
 FAX (574) 264-2169
 Http://www.shurflo.com
 © 2001

SHURflo Ltd. *
 Unit 5 Sterling Park
 Gatwick Road, Crawley
 West Sussex, RH10 2QT
 United Kingdom
 +44 1293 424000
 FAX +44 1293 421880

