

# General Purpose Pumps

## MARINE PRODUCT DATA SHEET

OEM: 8050-305-426

AFTERMARKET: 8050-305-426



Incorporating SHURflo's advance motor technology that includes thermal overload protection, these pumps are self-priming, easy to install and are extremely versatile-perfect for a variety of uses including winterizing, Oil changing and liquid transfer.

### TYPICAL APPLICATIONS

Oil change systems. Other uses may include 12 VDC pressurized water systems, winterizing, and liquid transfer. For other applications contact SHURflo.

### PUMP

Type: 3 Chamber Diaphragm  
Ports: 3/8" NPT-Female  
Liquid: 130 °F [54 °C] Max  
Prime: 6 feet [1.82 M]  
Inlet PSI: 30 PSI [2.1 Bar] Max  
Run Dry: Yes

### ELECTRICAL

Motor: 12VDC Permanent Magnet, Continuous Duty  
Protection: Thermal Overload  
Leads: 8 feet with alligator clips  
Fuse: 7.5 Amp Recommended  
Control: 30 PSI Internal By-Pass (No External Control)

### MATERIALS

Housing: Polypropylene  
Valves: Buna  
Diaphragm: Geolast 87 Shore  
Hardware: Stainless Steel

### APPROVALS

CE

### WARRANTY

1 Year Limited Warranty  
See SB-1041 & SB-1050 For Full Warranty Details

### SHIPPING

Net Weight (Boxed): 8 Lb [3.6 Kg] each  
Carton Weight: 1 each, 8 Lb [3.6 Kg]  
Carton Size: 13"L x 13"W x 13"H  
[33 cm x 33 cm x 33 cm]

### RELATED DOCUMENTS

Catalog: MS-030-140  
Installation Manual: 911-672  
Maintenance: 911-672  
Applications Spec Guide: MS-020-005  
Warranty: SB-1050

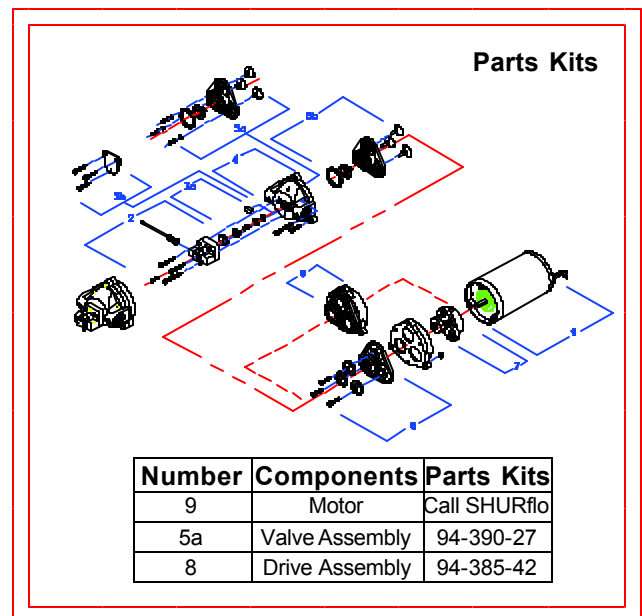

**PERFORMANCE @ 12V DC WITH WATER**

PRESSURE		FLOW		CURRENT
BAR	PSI	GPM	LPM	AMPS
0.0	0	1.55	5.86	2.2
0.7	10	1.45	5.48	2.8
1.4	20	1.36	5.14	3.5
2.1	30	1.10	4.16	4.1
2.8	40	0.15	0.56	4.4

**TYPICAL MOTOR SHELL T-RISE @ 40 PSI, 12V**

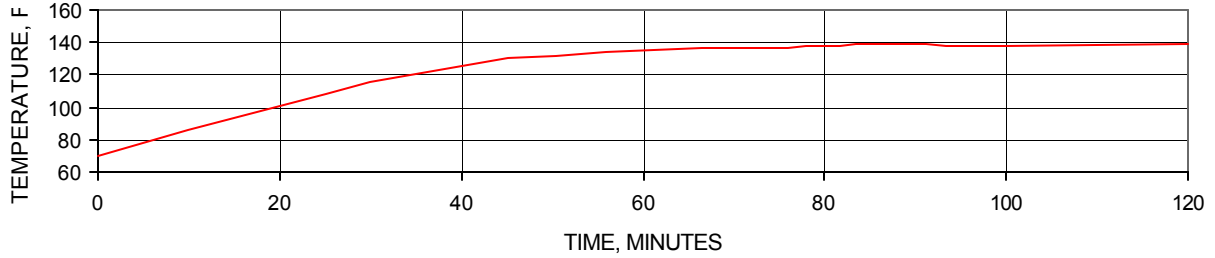

**DIMENSIONS [mm]**

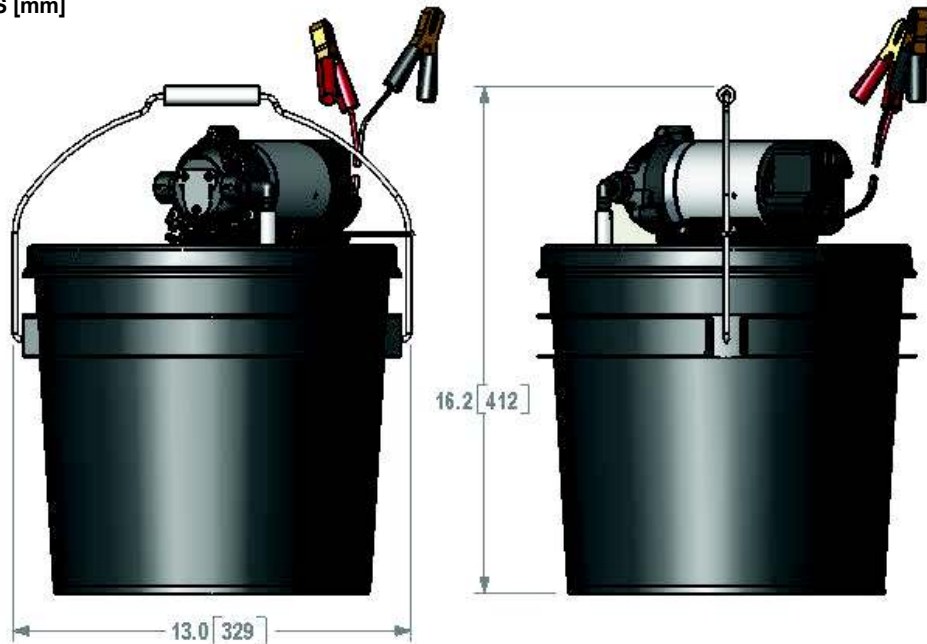

\*ISO Registered Facility *SHURflo reserves the right to update specifications, prices, or make substitutions.*

**SHURflo \***  
 5900A Katella Ave.  
 Cypress, Ca. 90630  
 (800) 854-3218 (562) 795-5200  
 FAX (562) 795-7554  
 Shipping/UPS: 5900C Katella Ave.  
 Cypress, Ca. 90630

**SHURflo East**  
 52748 Park Six Court  
 Elkhart, IN 46514-5427  
 (800) 762-809 (574) 262-0478  
 FAX (574) 264-2169  
 Http://www.shurflo.com  
 © 2001

**SHURflo Ltd. \***  
 Unit 5 Sterling Park  
 Gatwick Road, Crawley  
 West Sussex, RH10 2QT  
 United Kingdom  
 +44 1293 424000  
 FAX +44 1293 421880

