

SPECIFICATIONS:

- MODEL NUMBER:** 8035-963-239
- PUMP DESIGN:** Positive Displacement 3 Chamber Diaphragm Pump
- CHECK VALVE:** (2-Way Op.) Prevents Reverse Flow & 6 Ft. Head Forward Flow
- CAM:** 3.0 Degree
- MOTOR:** Permanent Magnet, P/N 11-223-00, Thermally Protected
- VOLTAGE:** 115 VAC Nominal
- PRESSURE SWITCH:** Adjustable Shut-Off (Range 140-160 PSI)
 Factory Set @ 150 PSI, Turn On 115 PSI
- LIQUID TEMPERATURE:** 180 Degrees Fahrenheit (82 Degrees Centigrade) Max.
- PRIME:** Self-Priming Up To 6 Ft. Vertical,
 Max. Inlet Pressure 30 PSI (2.1 Bar)
- PORTS:** 3/8"-18 NPT Female
- MATERIAL OF CONSTRUCTION:**
 - PLASTICS-** Nylon
 - VALVES-** EPDM
 - DIAPHRAGM-** Santoprene
 - FASTENERS-** Zinc Plated Steel
- NET WEIGHT:** 5.94 Lbs (2.7 Kg)
- DUTY CYCLE:** Intermittent (See Temperature Rise Chart)
- APPROVALS:** UL & CSA Recognized Component, NSF Listed
- TYPICAL APPLICATIONS:** Soil Extraction

DIMENSIONS:

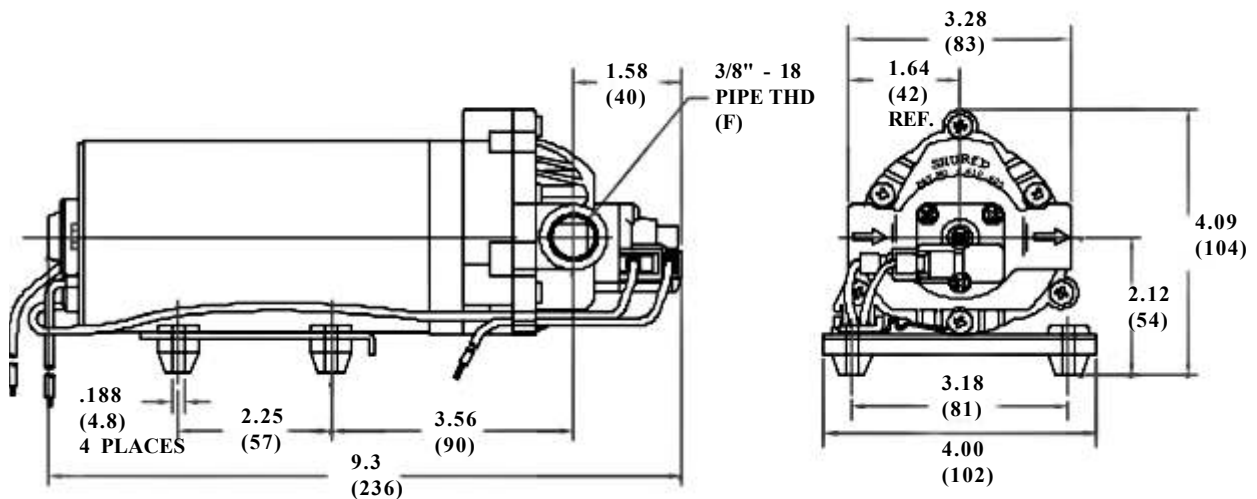

TEMPERATURE RISE

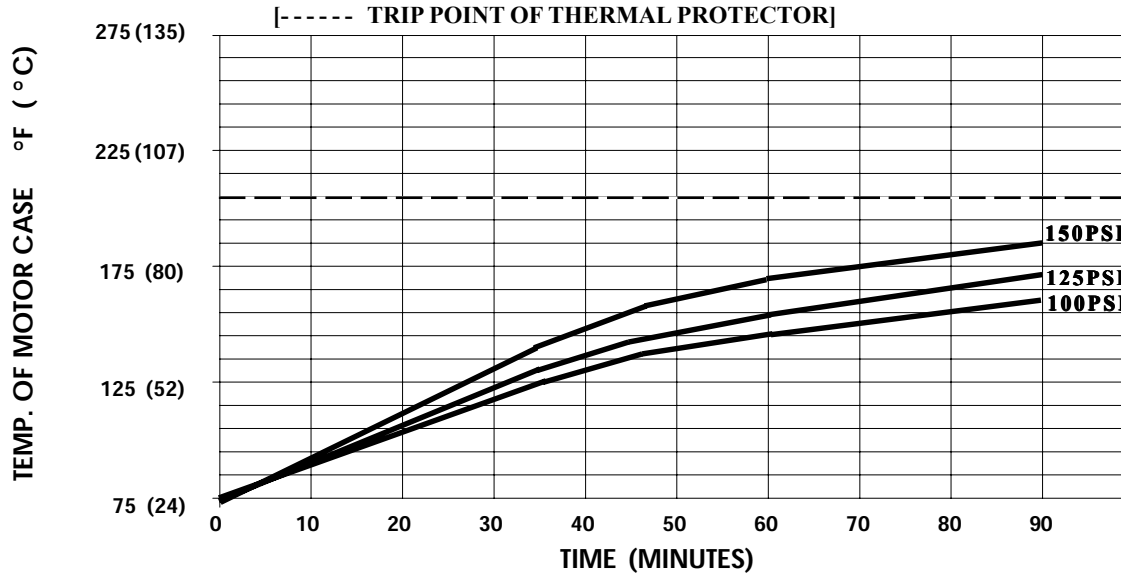

THIS GRAPH IS FOR USE AS A DESIGN GUIDE. IT IS BASED ON RUNNING CONTINUOUSLY WITH AN AMBIENT TEMPERATURE OF 75°F IN STILL AIR. THE THERMAL BREAKER WILL OPEN WHEN THE CASE TEMPERATURE REACHES 205°F.

TYPICAL PERFORMANCE

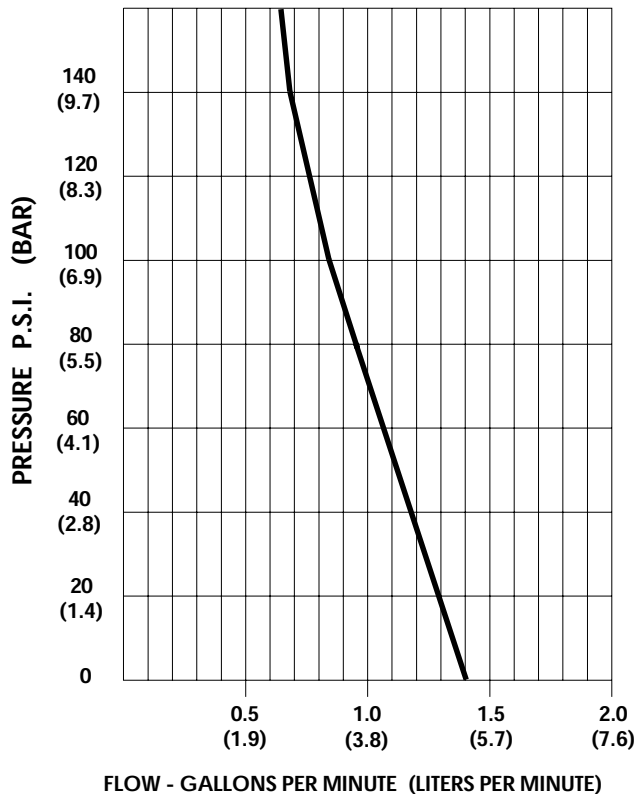

PRESSURE (PSI)	FLOW (GPM/LIT)	RPM MIN/MAX	CURRENT (AMPS)	VOLTAGE (VOLTS)
OPEN	1.40/5.3	1915/1925	0.30	115VAC
10	1.30/4.9	1875/1910	0.39	"
20	1.24/4.7	1820/1840	0.45	"
30	1.17/4.4	1785/1825	0.50	"
40	1.13/4.3	1730/1790	0.56	"
50	1.08/4.1	1675/1750	0.61	"
60	1.04/3.9	1660/1725	0.66	"
80	0.95/3.6	1590/1645	0.76	"
100	0.86/3.2	1525/1585	0.84	"
120	0.77/2.9	1475/1545	0.92	"
140	0.67/2.5	1440/1500	0.98	"
150	0.63/2.4	1420/1480	1.00	"

*-SPECIFICATIONS SUBJECT TO CHANGE WITHOUT NOTICE.
-ALL DATA BASED ON TESTING WITH WATER AT AMBIENT TEMPERATURE.*