

SPECIFICATIONS:

MODEL NUMBER: 8010-252-236
PUMP DESIGN: Positive Displacement 3 Chamber Diaphragm Pump
CHECK VALVE: (1-Way Operation) Prevents Reverse Flow
CAM: 2.5 Degree
MOTOR: Permanent Magnet, P/N 11-142-20, Thermally Protected
VOLTAGE: 24 VAC Nominal
PRESSURE SWITCH: Adjustable Shut-Off (Range 40-60 PSI)
Factory Set @ 60 PSI, Turn On 45 PSI ± 5 PSI
LIQUID TEMPERATURE: 170 Degrees Fahrenheit (77 Degrees Centigrade) Max.
PRIME: Self-Priming Up To 7.0 Ft. Vertical,
Max. Inlet Pressure 30 PSI (2.1 Bar)
PORTS: 3/8"-18 NPT Female
MATERIAL OF CONSTRUCTION:
PLASTICS- Polypropylene
VALVES- EPDM
DIAPHRAGM- Santoprene
FASTENERS- Stainless Steel
NET WEIGHT: 3.8 Lbs (1.72 Kg)
DUTY CYCLE: Intermittent (See Temperature Rise Chart)
APPROVALS: NSF Listed
TYPICAL APPLICATIONS: Booster Pump, Water Delivery

DIMENSIONS:

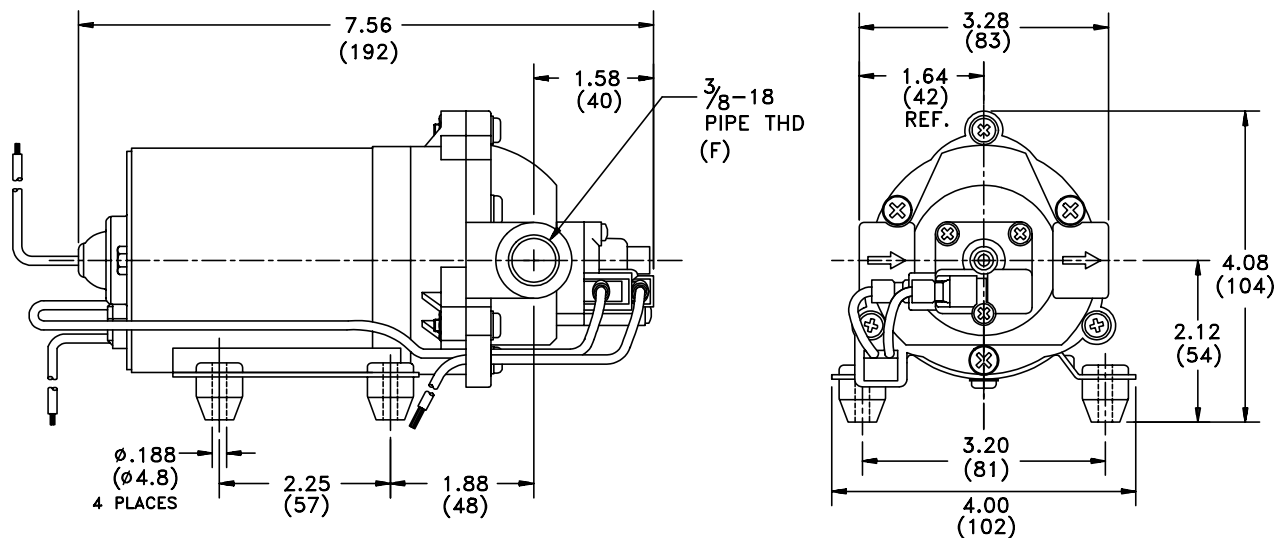

TEMPERATURE RISE

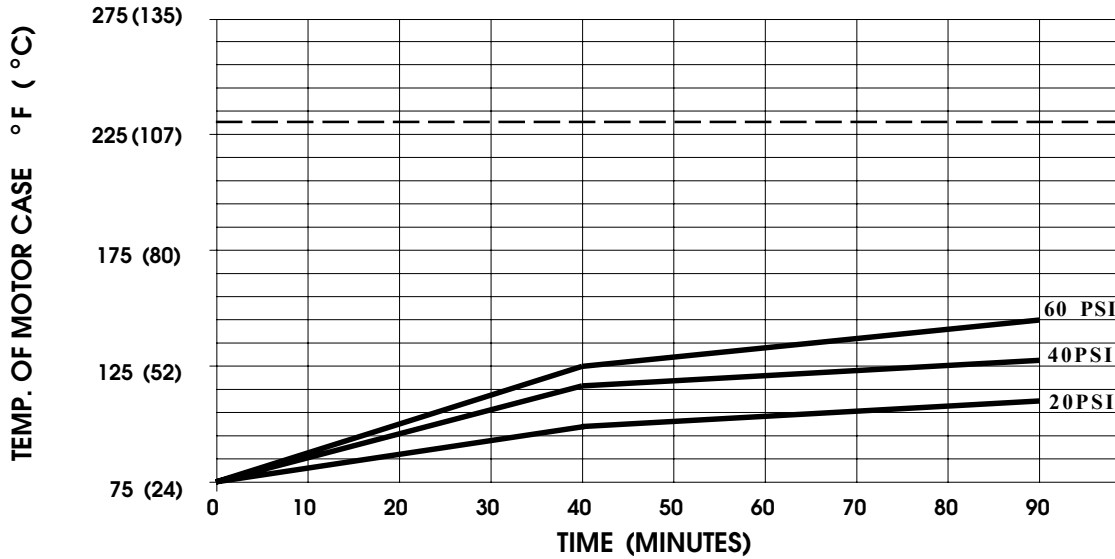

THIS GRAPH IS FOR USE AS A DESIGN GUIDE. IT IS BASED ON RUNNING CONTINUOUSLY WITH AN AMBIENT TEMPERATURE OF 75 °F IN STILL AIR. THE THERMAL BREAKER WILL OPEN WHEN THE CASE TEMPERATURE REACHES 230 °F.

[- - - - - TRIP POINT OF THERMAL PROTECTOR]

TYPICAL PERFORMANCE

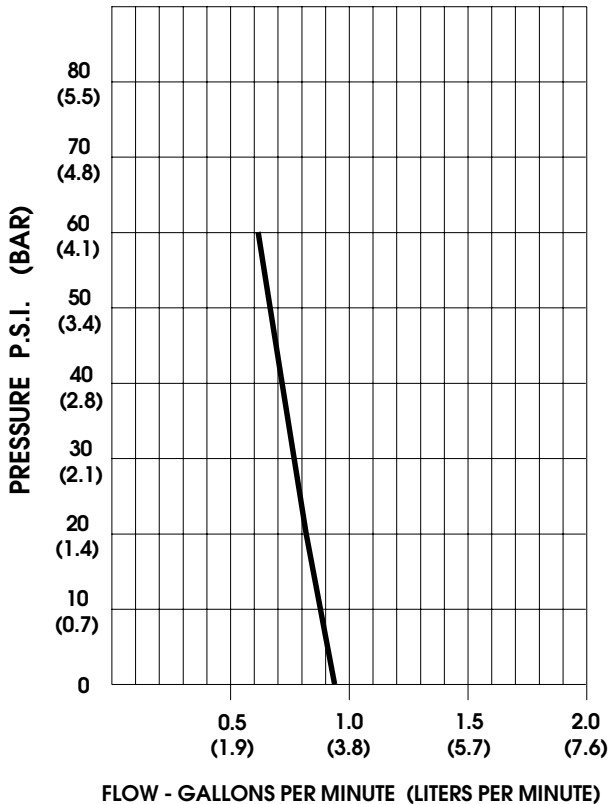

PRESSURE (PSI)	FLOW (GPM/LIT)	RPM MIN/MAX	CURRENT (AMPS)	VOLTAGE (VOLTS)
OPEN	0.95/3.6	1555/1625	0.82	24VAC
10	0.87/3.3	1500/1570	0.99	"
20	0.82/3.1	1445/1515	1.21	"
30	0.75/2.8	1385/1460	1.43	"
40	0.72/2.7	1325/1420	1.62	"
50	0.66/2.5	1290/1375	1.81	"
60	0.62/2.3	1240/1330	1.98	"

-SPECIFICATIONS SUBJECT TO CHANGE WITHOUT NOTICE.

-ALL DATA BASED ON TESTING WITH WATER AT AMBIENT TEMPERATURE.