

### SPECIFICATIONS:

**MODEL NUMBER:** 8007-547-250

**PUMP DESIGN:** Positive Displacement 3 Chamber Diaphragm Pump

**CAM:** 3.0 Degree

**MOTOR:** Permanent Magnet, P/N 11-184-03, On/Off Switch, Connector

**VOLTAGE:** 12 VDC Nominal

**PRESSURE SWITCH:** None

**LIQUID TEMPERATURE:** 170 Degrees Fahrenheit (77 Degrees Centigrade) Max.

**PRIME:** Self-Priming Up To 11 Ft. Vertical,  
Max. Inlet Pressure 30 PSI (2.1 Bar)

**PORTS:** 3/8"-18 NPT Female

**MATERIAL OF CONSTRUCTION:**

**PLASTICS-** Polypropylene

**VALVES-** Viton

**DIAPHRAGM-** Santoprene

**FASTENERS-** Cad or Zinc Plated Steel

**NET WEIGHT:** 4.6 Lbs (2.1 Kg)

**DUTY CYCLE:** Continuous (See Temperature Rise Chart)

**TYPICAL APPLICATIONS:** Agricultural Spraying

**BYPASS:** 45 PSI

### DIMENSIONS:

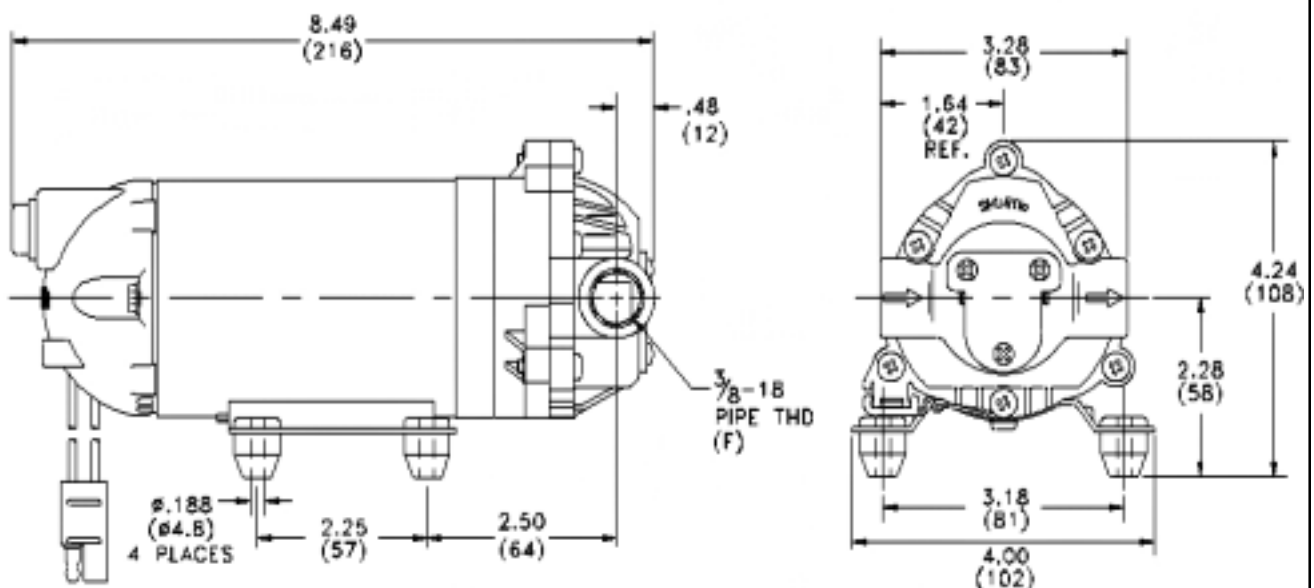

### TEMPERATURE RISE

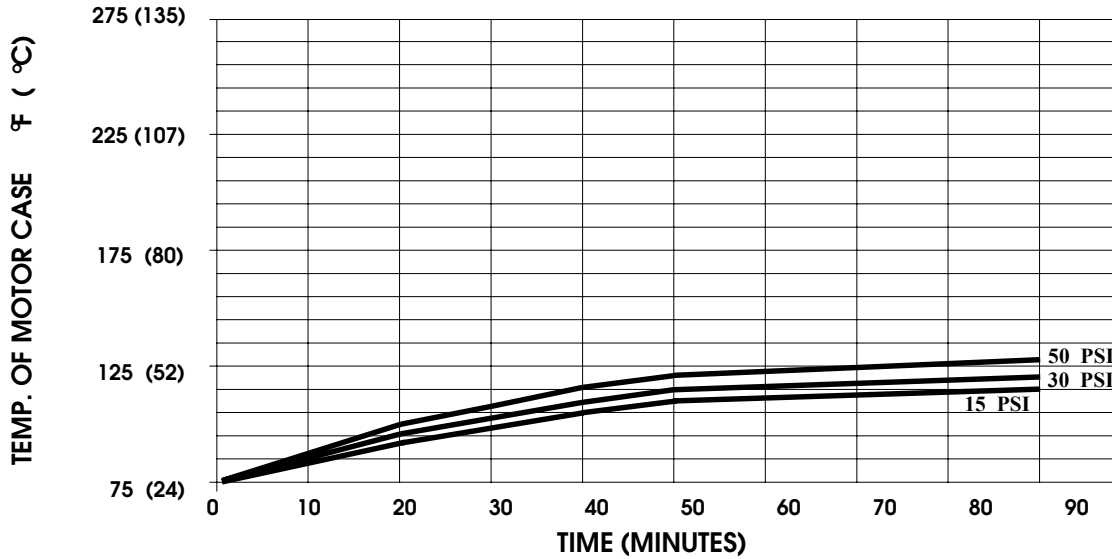

### TYPICAL PERFORMANCE

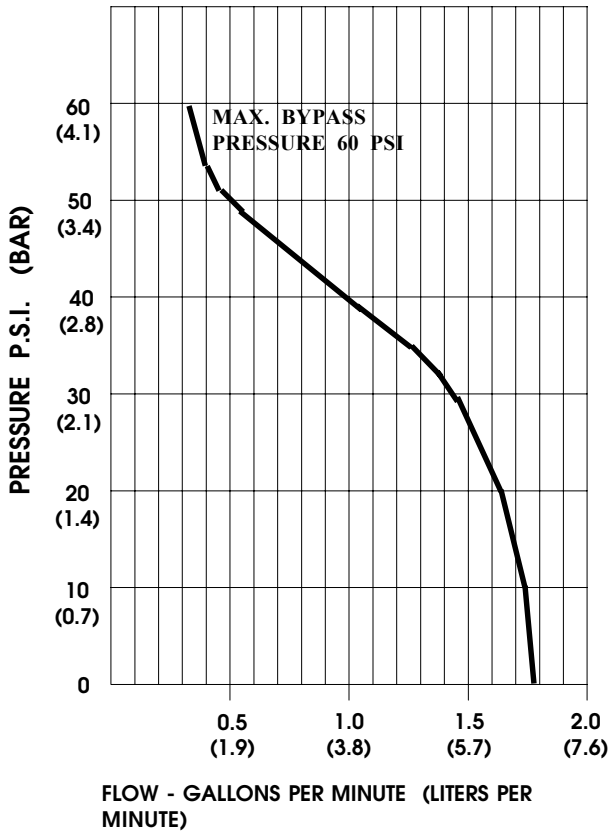

PRESSURE (PSI)	FLOW (GPM/LIT)	RPM MIN/MAX	CURRENT (AMPS)	VOLTAGE (VOLTS)
OPEN	1.80/6.8	2290/2345	3.0	12 VDC
10	1.40/5.3	2275/2335	3.4	"
20	1.30/4.9	2230/2300	4.0	"
30	1.11/4.2	2190/2255	4.7	"
40	0.69/2.6	2165/2230	5.2	"
50	0.18/0.7	2140/2200	5.5	"

-SPECIFICATIONS SUBJECT TO CHANGE WITHOUT NOTICE.

-ALL DATA BASED ON TESTING WITH WATER AT AMBIENT TEMPERATURE.