

SPECIFICATIONS:

MODEL NUMBER: 8006-943-238

PUMP DESIGN: Positive Displacement 3 Chamber Diaphragm Pump

CHECK VALVE: (1-Way Operation) Prevents Reverse Flow

CAM: 3.0 Degree

MOTOR: Permanent Magnet, P/N 11-111-07

VOLTAGE: 12 VDC Nominal

PRESSURE SWITCH: Adjustable Shut-Off (Range 80-100 PSI)

Factory Set @100 PSI, Turn On 85 PSI \pm 5 PSI

LIQUID TEMPERATURE: 180 Degrees Fahrenheit (82 Degrees Centigrade) Max.

PRIME: Self-Priming Up To 13 Ft. Vertical,
Max. Inlet Pressure 30 PSI (2.1 Bar)

PORTS: 3/8"-18 NPT Female

MATERIAL OF CONSTRUCTION:

PLASTICS- Nylon

VALVES- EPDM

DIAPHRAGM- Santoprene

FASTENERS- Zinc or Cad Plated Steel

NET WEIGHT 4.6 Lbs (2.08 Kg)

DUTY CYCLE: Intermittent (See Temperature Rise Chart)

TYPICAL APPLICATIONS: Soil Extraction

DIMENSIONS:

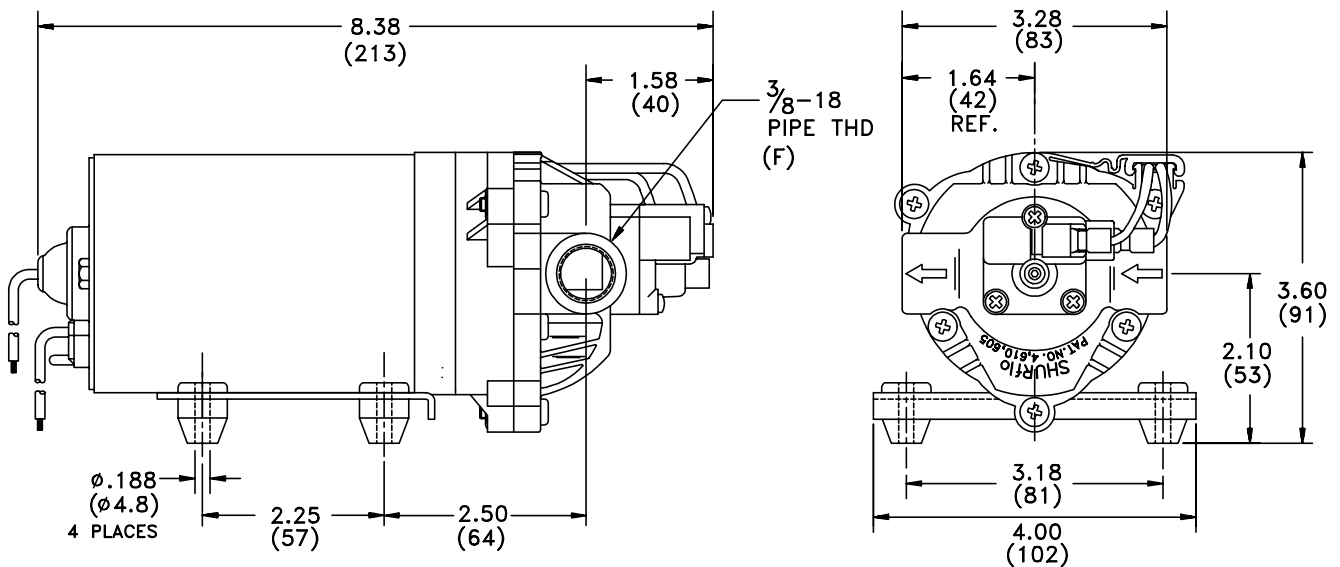

TEMPERATURERISE

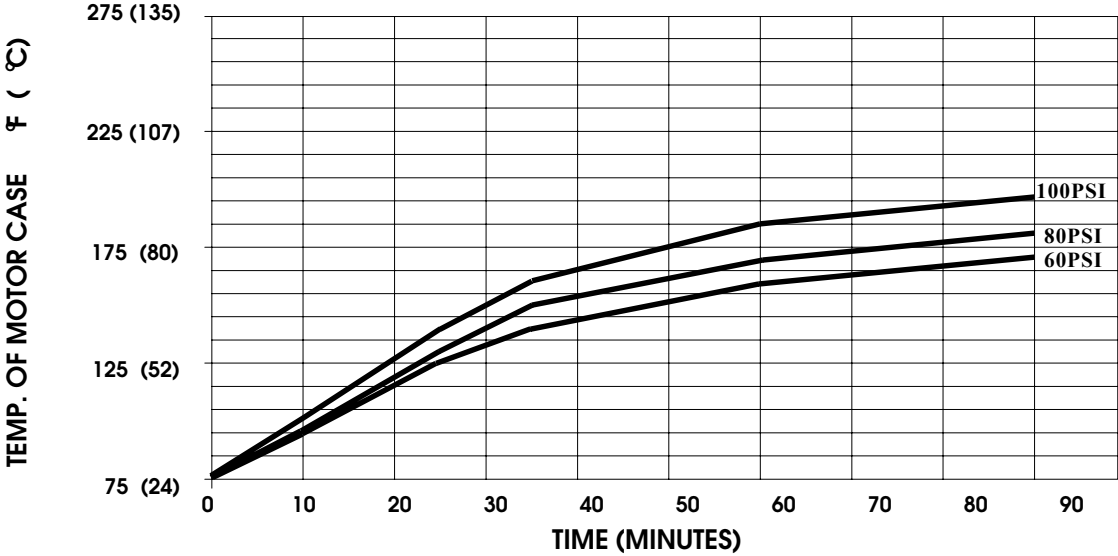

THIS GRAPH IS FOR USE AS A DESIGN GUIDE. IT IS BASED ON RUNNING CONTINUOUSLY WITH AN AMBIENT TEMPERATURE OF 75° F IN STILL AIR.

TYPICAL PERFORMANCE

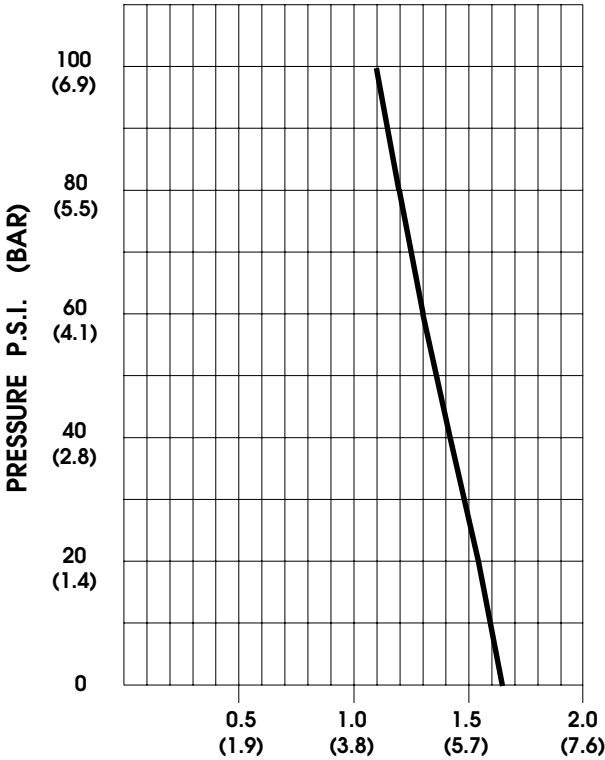

PRESSURE (PSI)	FLOW (GPM/LIT)	RPM MIN/MAX	CURRENT (AMPS)	VOLTAGE (VOLTS)
OPEN	1.65/6.2	2160/2170	3.6	24VDC
10	1.60/6.0	2140/2150	4.0	"
20	1.53/5.8	2085/2100	4.7	"
30	1.46/5.5	2030/2055	5.5	"
40	1.39/5.3	2000/2015	6.1	"
50	1.35/5.1	1940/1980	6.8	"
60	1.29/4.9	1900/1945	7.4	"
70	1.25/4.7	1850/1910	8.1	"
80	1.21/4.6	1795/1880	8.7	"
90	1.16/4.4	1755/1835	9.2	"
100	1.11/4.2	1710/1795	9.8	"

FLOW - GALLONS PER MINUTE (LITERS PER MINUTE)

*-SPECIFICATIONS SUBJECT TO CHANGE WITHOUT NOTICE.
 -ALL DATA BASED ON TESTING WITH WATER AT AMBIENT TEMPERATURE.*