

### SPECIFICATIONS:

**MODEL NUMBER:** 8000-882-288

**PUMP DESIGN:** Positive Displacement 3 Chamber Diaphragm Pump

**CHECK VALVE:** (2-Way Op.) Prevents Reverse Flow & 6 Ft. Head Forward Flow

**CAM:** 2.5 Degree

**MOTOR:** Permanent Magnet, P/N 11-119-06

**VOLTAGE:** 36 VDC Nominal

**PRESSURE SWITCH:** Adjustable Shut-Off (Range 80-100 PSI)

Factory Set @ 100 PSI, Turn On 85 PSI ± 5 PSI

**LIQUID TEMPERATURE:** 180 Degrees Fahrenheit (82 Degrees Centigrade) Max.

**PRIME:** Self-Priming Up To 5.0 Ft. Vertical,  
Max. Inlet Pressure 30 PSI (2.1 Bar)

**PORTS:** 3/8"-18 NPT Female

**MATERIAL OF CONSTRUCTION:**

**PLASTICS-** Nylon

**VALVES-** Viton

**DIAPHRAGM-** Viton (Switch), Santoprene (Main)

**FASTENERS-** Zinc Plated Steel

**NET WEIGHT:** 5.2 Lbs (2.36 Kg)

**DUTY CYCLE:** Continuous (See Temperature Rise Chart)

**TYPICAL APPLICATIONS:** Soil Extraction

**BYPASS:** 80 PSI

### DIMENSIONS:

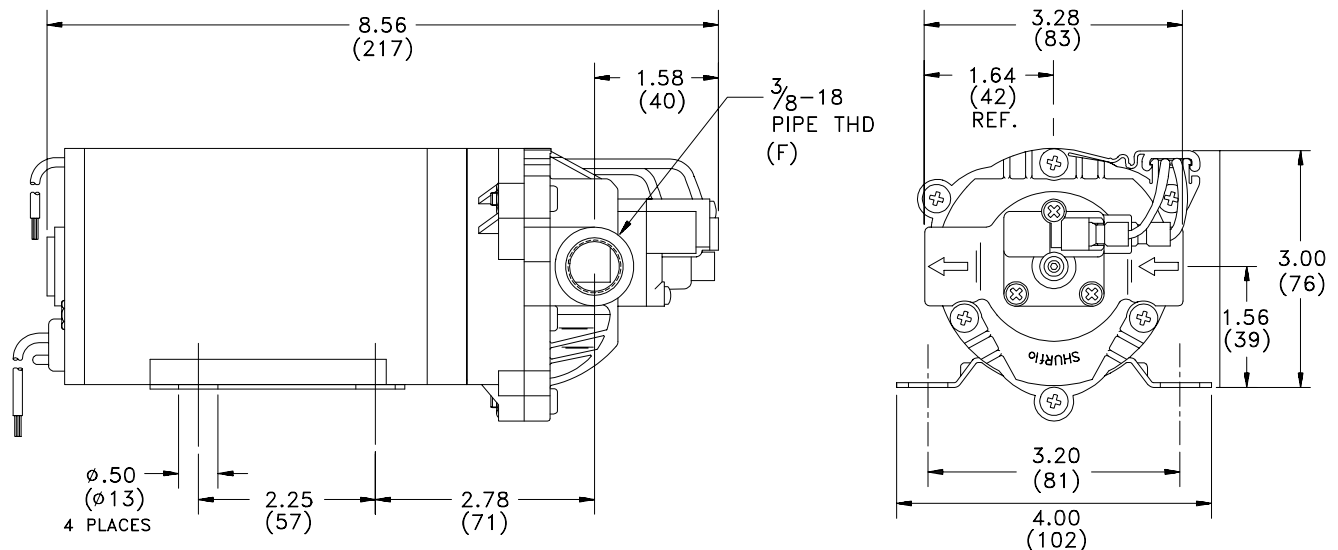

**TEMPERATURE RISE**

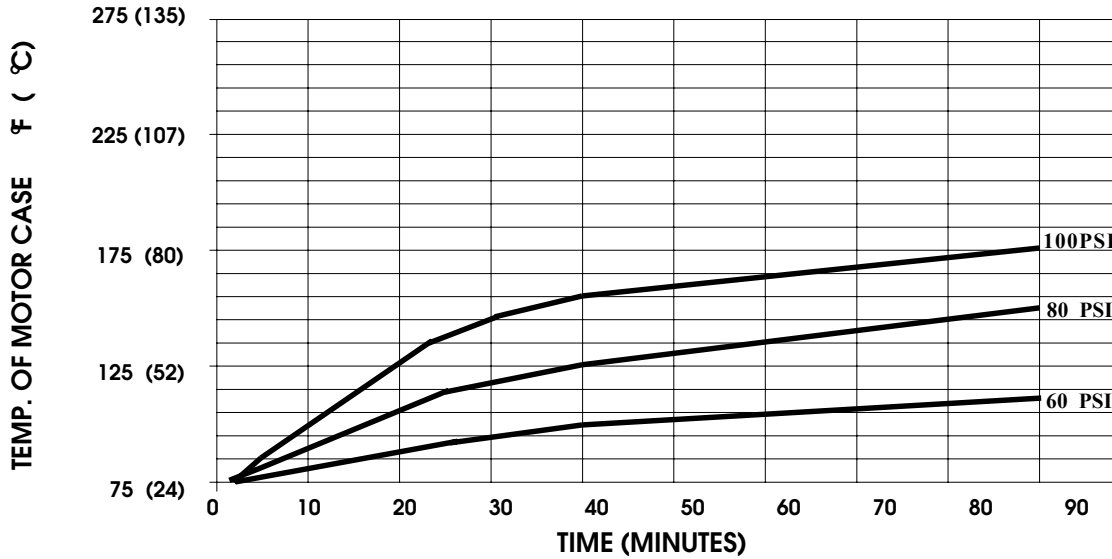

THIS GRAPH IS FOR USE AS A DESIGN GUIDE. IT IS BASED ON RUNNING CONTINUOUSLY WITH AN AMBIENT TEMPERATURE OF 70° F IN STILL AIR.

**TYPICAL PERFORMANCE**

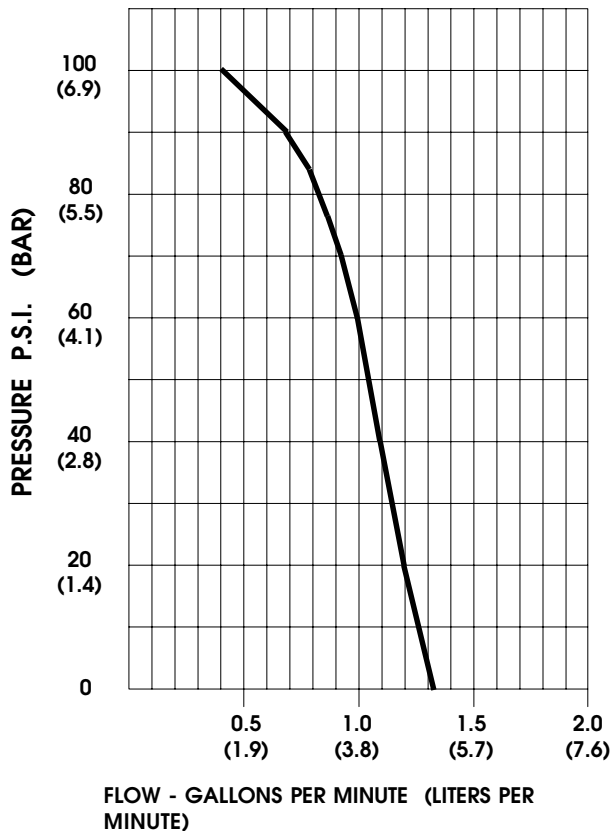

PRESSURE (PSI)	FLOW (GPM/LIT)	RPM MIN/MAX	CURRENT (AMPS)	VOLTAGE (VOLTS)
OPEN	1.33/5.0	2340/2390	0.8	36 VDC
10	1.27/4.8	2305/2340	0.9	"
20	1.20/4.5	2275/2310	1.1	"
30	1.14/4.3	2240/2270	1.3	"
40	1.09/4.1	2210/2240	1.4	"
50	1.04/3.9	2185/2210	1.6	"
60	0.99/3.7	2155/2180	1.7	"
70	0.93/3.5	2125/2145	1.9	"
80	0.81/3.1	2095/2110	2.0	"
90	0.68/2.6	2065/2080	2.1	"
100	0.41/1.6	2040/2030	2.2	"

*-SPECIFICATIONS SUBJECT TO CHANGE WITHOUT NOTICE.*

*-ALL DATA BASED ON TESTING WITH WATER AT AMBIENT TEMPERATURE.*