

SPECIFICATIONS:

MODEL NUMBER: 8006-812-288

PUMP DESIGN: Positive Displacement 3 Chamber Diaphragm Pump

CHECK VALVE: (2-Way Op.) Prevents Reverse Flow and 6 Ft. Head Forward Flow

CAM: 2.5 Degree

MOTOR: Permanent Magnet, P/N 11-150-17, Thermally Protected

VOLTAGE: 115 VAC Nominal

PRESSURE SWITCH: Adjustable Shut-Off (Range 80-100 PSI)

Factory Set @100 PSI, Turn On 85 PSI +/- 5 PSI

LIQUID TEMPERATURE: 180 Degrees Fahrenheit (82 Degrees Centigrade) Max.

PRIME: Self-Priming Up To 7.0 Ft. Vertical,
Max. Inlet Pressure 30 PSI (2.1 Bar)

PORTS: 3/8"-18 NPT, Female

MATERIAL OF CONSTRUCTION:

PLASTICS- Nylon

VALVES- Viton

DIAPHRAGM- Viton (Switch), Santoprene (Main)

FASTENERS- Zinc Plated Steel

NET WEIGHT: 4.9 Lbs (2.2 Kg)

DUTY CYCLE: Intermittent (See Temperature Rise Chart)

APPROVALS: UL/CSA Recognized

TYPICAL APPLICATIONS: Soil Extraction

BYPASS: 80 PSI

DIMENSIONS:

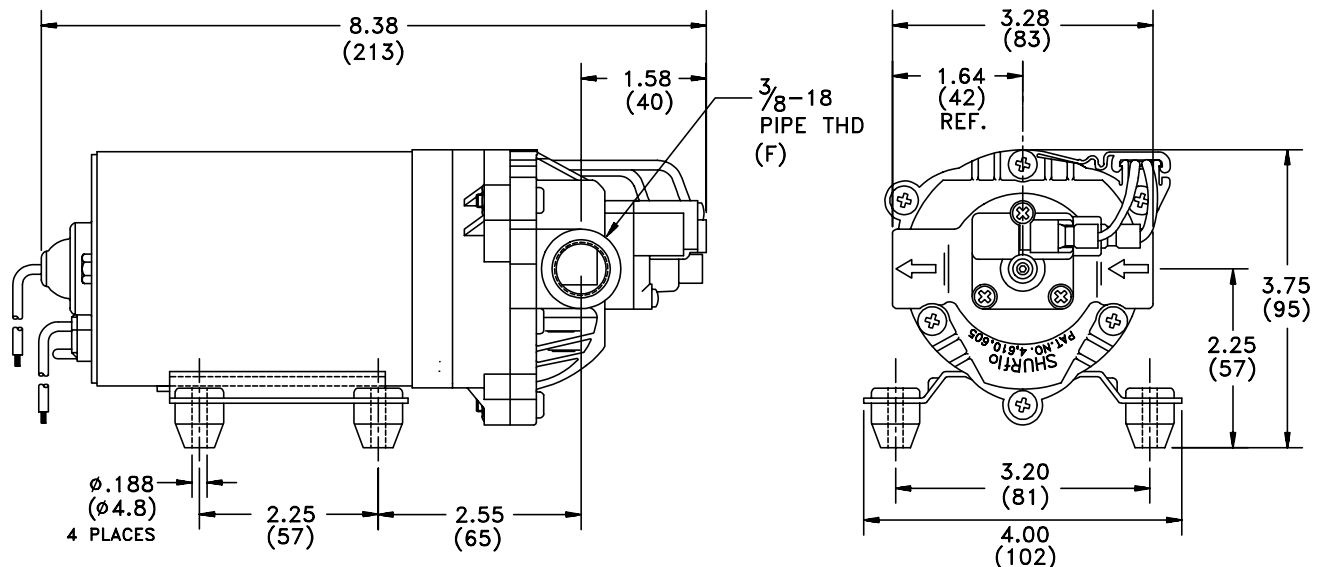

TEMPERATURE RISE

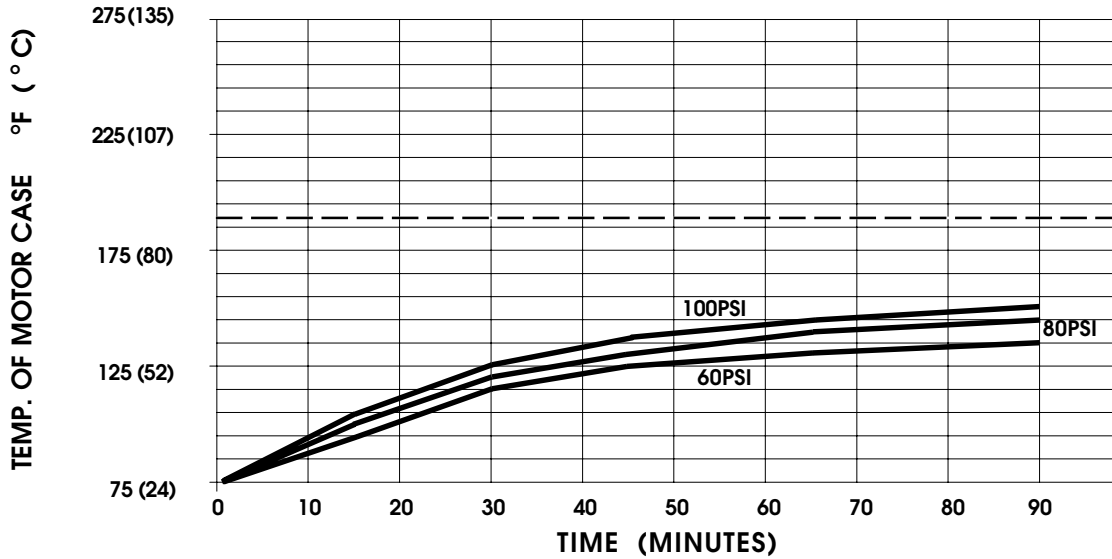

THIS GRAPH IS FOR USE AS A DESIGN GUIDE. IT IS BASED ON RUNNING CONTINUOUSLY WITH AN AMBIENT TEMPERATURE OF 70°F IN STILL AIR. THE THERMAL BREAKER WILL OPEN WHEN THE CASE TEMPERATURE REACHES 190°F.

[----- TRIP POINT OF THERMAL PROTECTOR]

TYPICAL PERFORMANCE

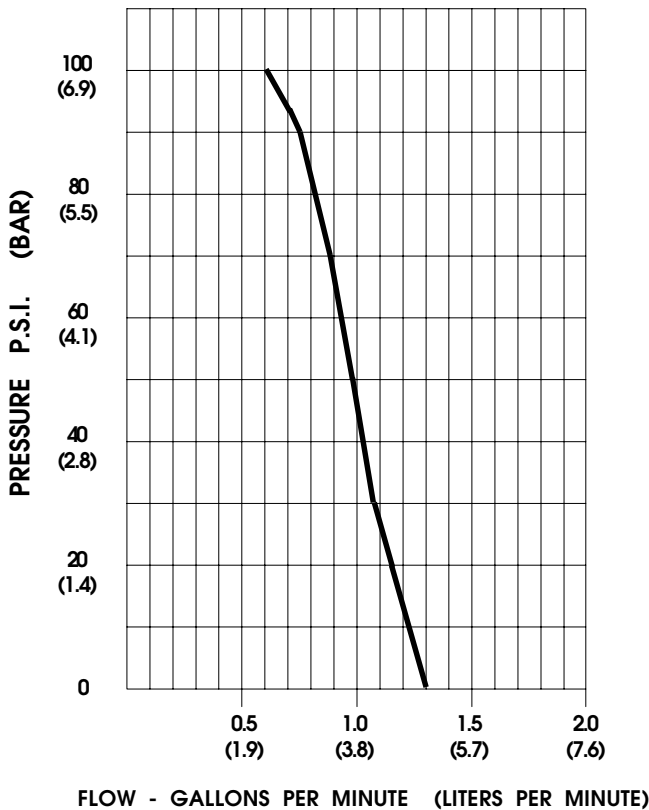

PRESSURE (PSI)	FLOW (GPM/LIT)	RPM MIN/MAX	CURRENT (AMPS)	VOLTAGE (VOLTS)
OPEN	1.30/4.9	2195/2290	0.30	115 VAC
10	1.21/4.6	2185/2215	0.35	"
20	1.13/4.3	2100/2160	0.39	"
30	1.06/4.0	2035/2100	0.43	"
40	1.02/3.9	1975/2050	0.47	"
50	0.96/3.6	1940/2000	0.51	"
60	0.94/3.5	1890/1950	0.55	"
70	0.89/3.4	1850/1915	0.58	"
80	0.82/3.1	1805/1875	0.61	"
90	0.73/2.8	1775/1850	0.64	"
100	0.60/2.3	1735/1810	0.67	"

-SPECIFICATIONS SUBJECT TO CHANGE WITHOUT NOTICE.

-ALL DATA BASED ON TESTING WITH WATER AT AMBIENT TEMPERATURE.