

SPECIFICATIONS:

MODEL NUMBER: 8006-783-138

PUMP DESIGN: Positive Displacement 3 Chamber Diaphragm Pump

CHECK VALVE: (1-Way Operation) Prevents Reverse Flow

CAM: 3.0 Degree

MOTOR: Permanent Magnet, P/N 11-119-06

VOLTAGE: 36 VDC Nominal

PRESSURE SWITCH: Adjustable Shut-Off (Range 80-100 PSI)

Factory Set @ 100 PSI, Turn On 85 PSI \pm 5 PSI

LIQUID TEMPERATURE: 180 Degrees Fahrenheit (82 Degrees Centigrade) Max.

PRIME: Self-Priming Up To 12 Ft. Vertical,
Max. Inlet Pressure 30 PSI (2.1 Bar)

PORTS: 1/2" - 14 Male Parallel Thread

MATERIAL OF CONSTRUCTION:

PLASTICS- Nylon

VALVES- EPDM

DIAPHRAGM- Santoprene

FASTENERS- Zinc Plated Steel

NET WEIGHT: 5.1 Lbs (2.3 Kg)

DUTY CYCLE: Continuous (See Temperature Rise Chart)

TYPICAL APPLICATIONS: Soil Extraction

DIMENSIONS:

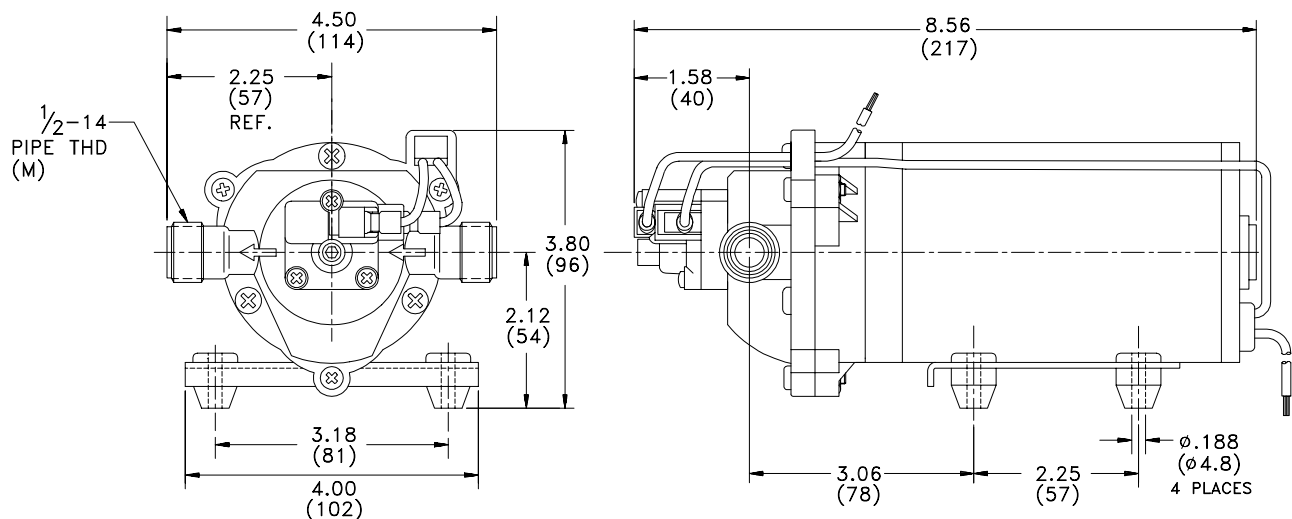

TEMPERATURE RISE

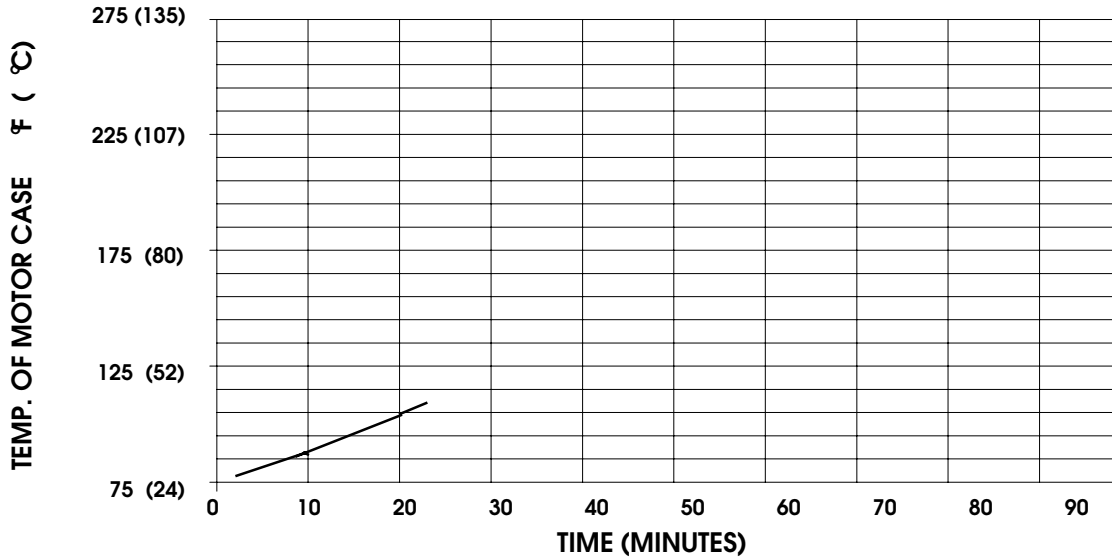

TYPICAL PERFORMANCE

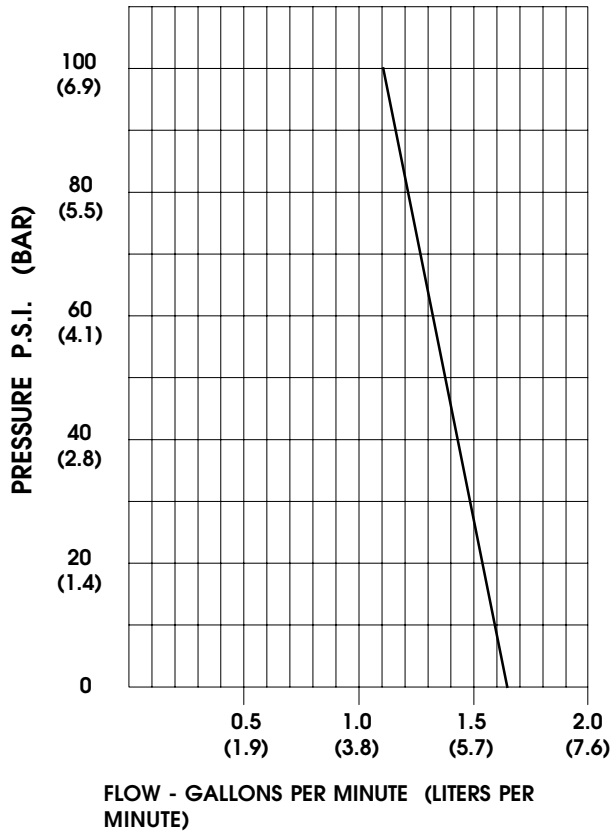

PRESSURE (PSI)	FLOW (GPM/LIT)	RPM MIN/MAX	CURRENT (AMPS)	VOLTAGE (VOLTS)
OPEN	1.63/6.2	2330/2435	0.91	36VDC
10	1.58/6.0	2300/2395	1.13	
20	1.52/5.7	2245/2335	1.40	
30	1.47/5.5	2165/2280	1.64	
40	1.40/5.3	2150/2225	1.88	
50	1.35/5.1	2105/2175	2.11	
60	1.30/4.9	2070/2125	2.32	
70	1.24/4.7	2025/2080	2.54	
80	1.19/4.5	1985/2030	2.73	
90	1.16/4.4	1935/1985	2.93	
100	1.10/4.1	1900/1935	3.10	

-SPECIFICATIONS SUBJECT TO CHANGE WITHOUT NOTICE.

-ALL DATA BASED ON TESTING WITH WATER AT AMBIENT TEMPERATURE.