

SPECIFICATIONS:

MODEL NUMBER: 8005-952-480

PUMP DESIGN: Positive Displacement 3 Chamber Diaphragm Pump

CAM: 2.5 Degree

MOTOR: Permanent Magnet, P/N 11-147-13

VOLTAGE: 24/36 VDC Nominal

PRESSURE SWITCH: None

LIQUID TEMPERATURE: 180 Degrees Fahrenheit (82 Degrees Centigrade) Max.

PORTS: 3/8"-18 NPT Female

MATERIAL OF CONSTRUCTION:

PLASTICS- Nylon

VALVES- EPDM

DIAPHRAGM- Santoprene

FASTENERS- Stainless Steel

NET WEIGHT: 4.8 Lbs (2.2 Kg)

DUTY CYCLE: Continuous (See Temperature Rise Chart)

APPROVALS: N.S.F. Listed

TYPICAL APPLICATIONS: R.O. Booster Pump

BYPASS: 80 to 110 PSI Max.

DIMENSIONS:

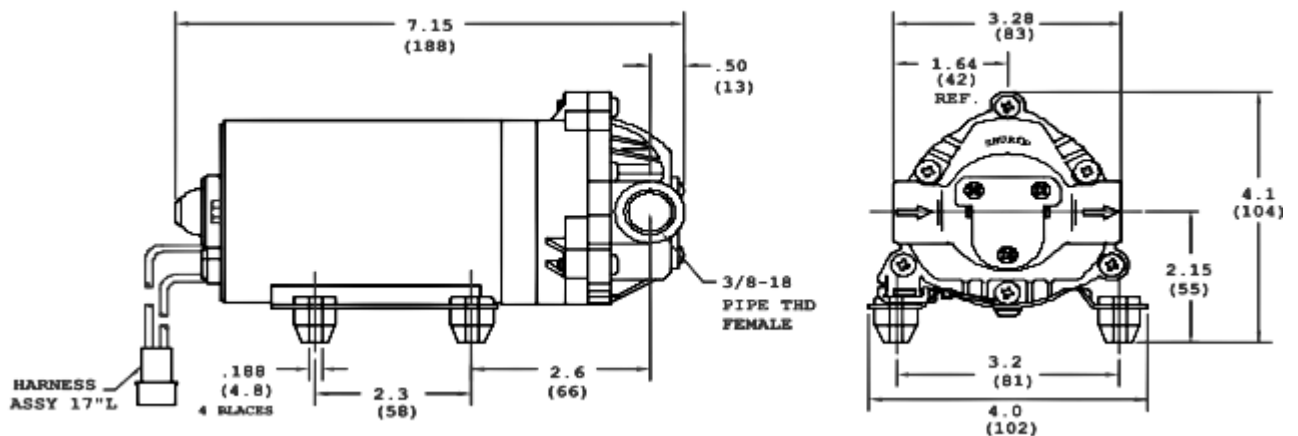

TEMPERATURE RISE

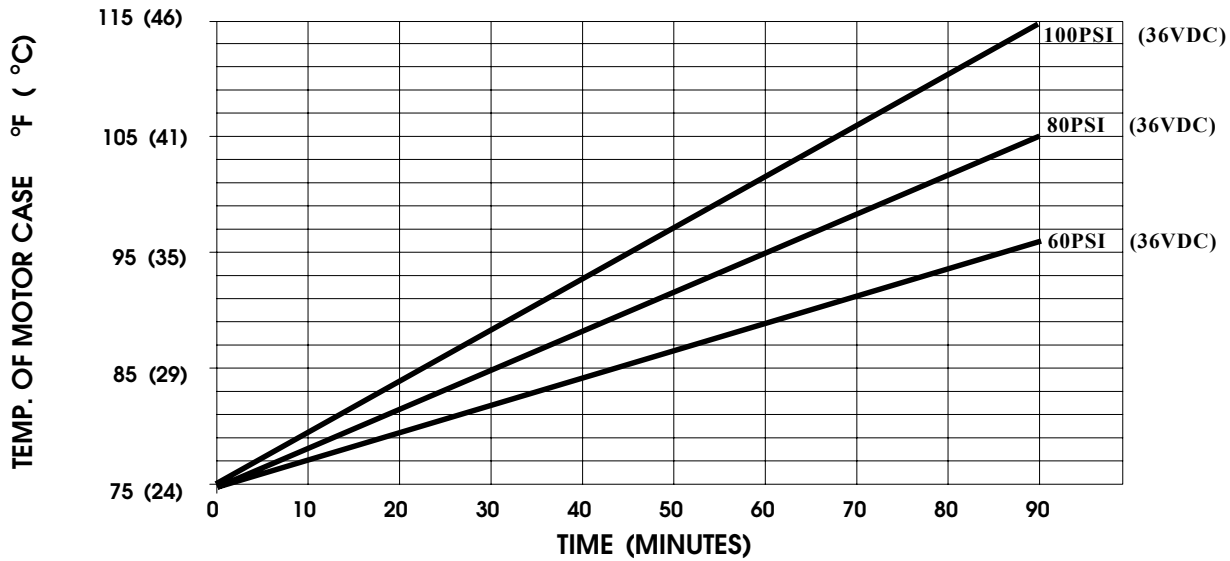

THIS GRAPH IS FOR USE AS A DESIGN GUIDE. IT IS BASED ON RUNNING CONTINUOUSLY WITH AN AMBIENT TEMPERATURE OF 75° F IN STILL AIR.

TYPICAL PERFORMANCE

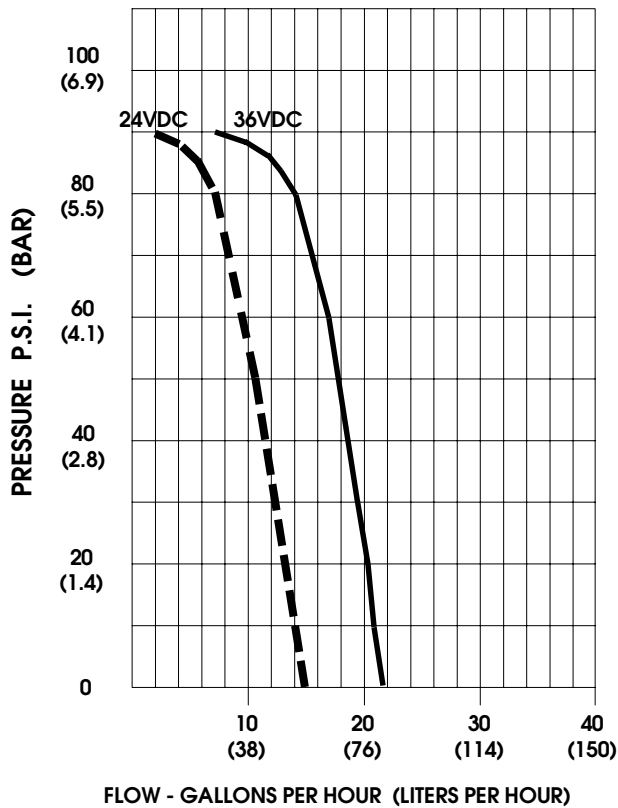

PRESSURE (PSI)	FLOW (GPH/LIT)	RPM MIN/MAX	CURRENT (AMPS)	VOLTAGE (VOLTS)
OPEN	21.8/82	660/670	0.13	
10	20.7/78	635/645	0.19	
20	20.3/77	615/620	0.26	
30	19.5/74	590/600	0.32	
40	18.7/71	570/580	0.37	
50	17.7/67	550/560	0.43	
60	16.9/64	535/545	0.48	
70	16.0/60	515/530	0.53	
80	14.0/53	495/505	0.59	
90	6.5/25	470/490	0.64	

*-SPECIFICATIONS SUBJECT TO CHANGE WITHOUT NOTICE.
-ALL DATA BASED ON TESTING WITH WATER.*