

SPECIFICATIONS:

MODEL NUMBER: 8005-912-290
PUMP DESIGN: Positive Displacement 3 Chamber Diaphragm Pump
CAM: 2.5 Degree
MOTOR: Permanent Magnet, P/N 11-150-10, Thermally Protected
VOLTAGE: 115 VAC Nominal
PRESSURE SWITCH: None
LIQUID TEMPERATURE: 180 Degrees Fahrenheit (82 Degrees Centigrade) Max.
PRIME: Self-Priming Up To 12 Ft. Vertical,
Max. Inlet Pressure 30 PSI (2.1 Bar)
PORTS: 3/8"-18 NPT Female
MATERIAL OF CONSTRUCTION:
PLASTICS- Nylon
VALVES- EPDM
DIAPHRAGM- Santoprene
FASTENERS- Zinc Plated Steel
NET WEIGHT: 4.6 Lbs (2.1 Kg)
DUTY CYCLE: Intermittent (See Temperature Rise Chart)
APPROVALS: NSF Listed, UL/CSA Recognized Component
TYPICAL APPLICATIONS: Carbonator
BYPASS: 100 PSI Bypass Springs

DIMENSIONS:

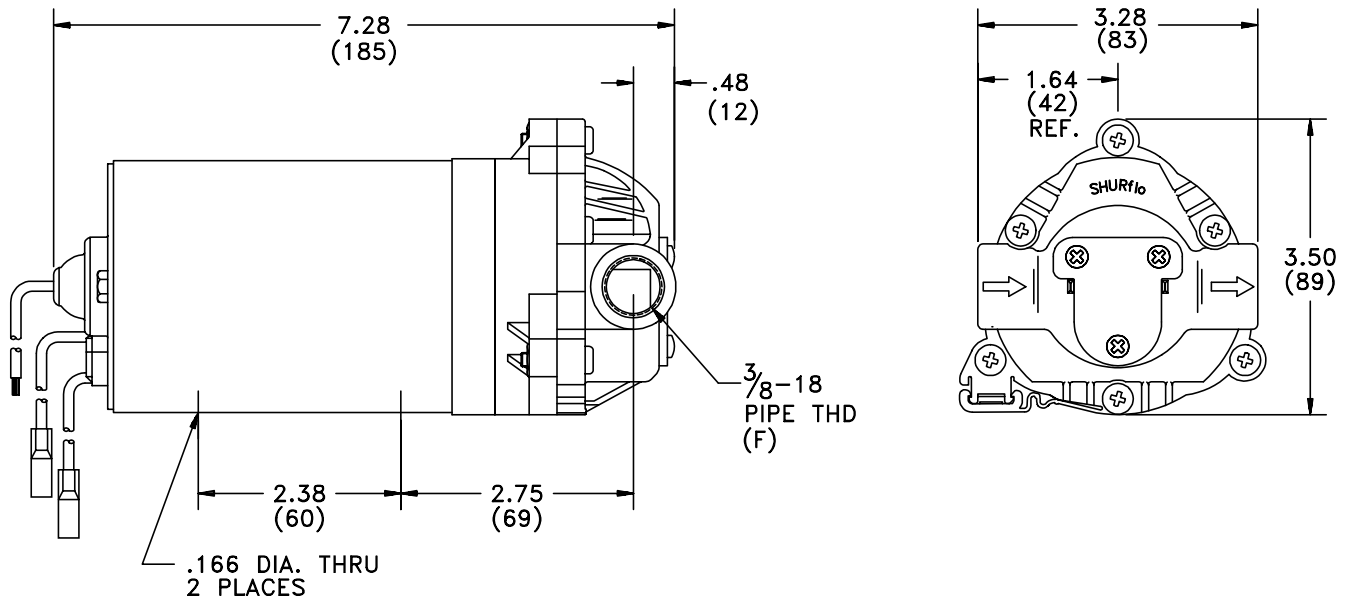

TEMPERATURE RISE

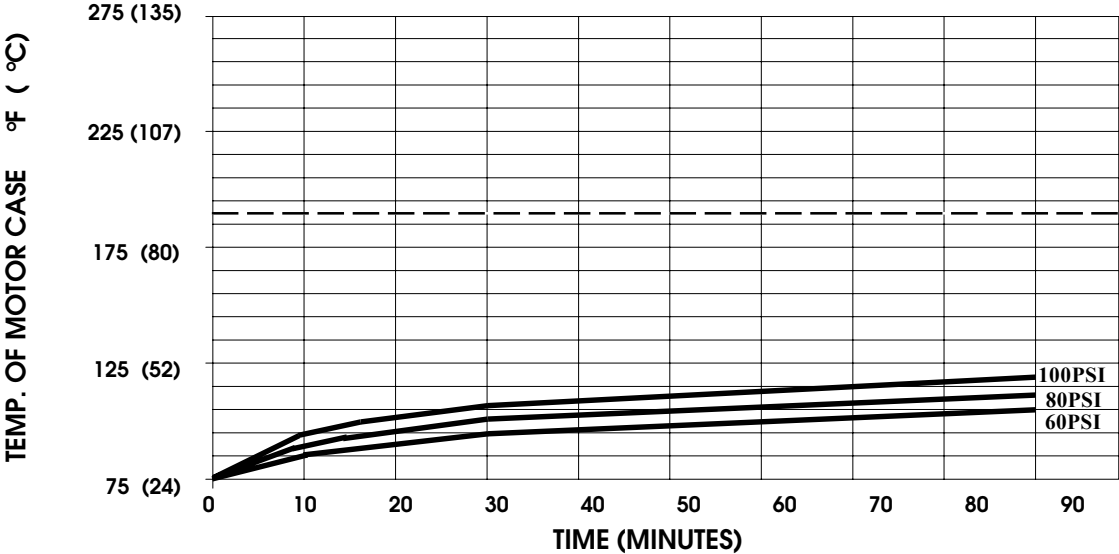

THIS GRAPH IS FOR USE AS A DESIGN GUIDE. IT IS BASED ON RUNNING CONTINUOUSLY WITH AN AMBIENT TEMPERATURE OF 75°F IN STILL AIR. THE THERMAL BREAKER WILL OPEN WHEN THE CASE TEMPERATURE REACHES 190° F.

[----- TRIP POINT OF THERMAL PROTECTOR]

TYPICAL PERFORMANCE

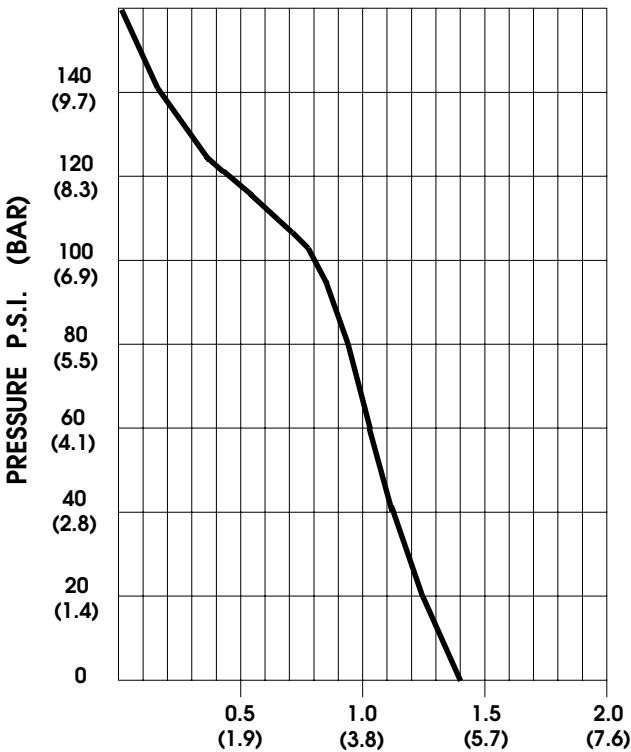

PRESSURE (PSI)	FLOW (GPM/LIT)	RPM MIN/MAX	CURRENT (AMPS)	VOLTAGE (VOLTS)
OPEN	1.40/5.3	2205/2245	0.34	115 VAC
10	1.35/5.1	2160/2205	0.38	"
20	1.25/4.7	2100/2120	0.42	"
30	1.18/4.5	2045/2065	0.48	"
40	1.12/4.2	1955/1965	0.53	"
50	1.06/4.0	1905/1910	0.58	"
60	1.01/3.8	1850/1885	0.63	"
70	0.97/3.6	1815/1840	0.68	"
80	0.94/3.5	1765/1785	0.72	"
100	0.83/3.1	1685/1705	0.81	"
120	0.40/1.5	1590/1615	0.89	"

*-SPECIFICATIONS SUBJECT TO CHANGE WITHOUT NOTICE.
 -ALL DATA BASED ON TESTING WITH WATER AT AMBIENT TEMPERATURE.*