

SPECIFICATIONS:

MODEL NUMBER: 8000-933-536

PUMP DESIGN: Positive Displacement 3 Chamber Diaphragm Pump

CHECK VALVE: (1-Way Operation) Prevents Reverse Flow

CAM: 3.0 Degree

MOTOR: Permanent Magnet, P/N 11-150-00, Thermally Protected

VOLTAGE: 115 VAC Nominal

PRESSURE SWITCH: Adjustable Shut-Off (Range 45-65 PSI)
Factory Set @ 65 PSI, Turn On 50 PSI \pm 5 PSI

LIQUID TEMPERATURE: 180 Degrees Fahrenheit (82 Degrees Centigrade) Max.

PRIME: Self-Priming Up To 11 Ft. Vertical,
Max. Inlet Pressure 30 PSI (2.1 Bar)

PORTS: 3/8"-18 NPT Female

MATERIAL OF CONSTRUCTION:

PLASTICS- Nylon

VALVES- EPDM

DIAPHRAGM- Santoprene

FASTENERS- Zinc Plated Steel

NET WEIGHT: 3.7 Lbs (1.7 Kg)

DUTY CYCLE: Intermittent (See Temperature Rise Chart)

APPROVALS: UL & CSA Recognized Component

TYPICAL APPLICATIONS: Soil Extraction

DIMENSIONS:

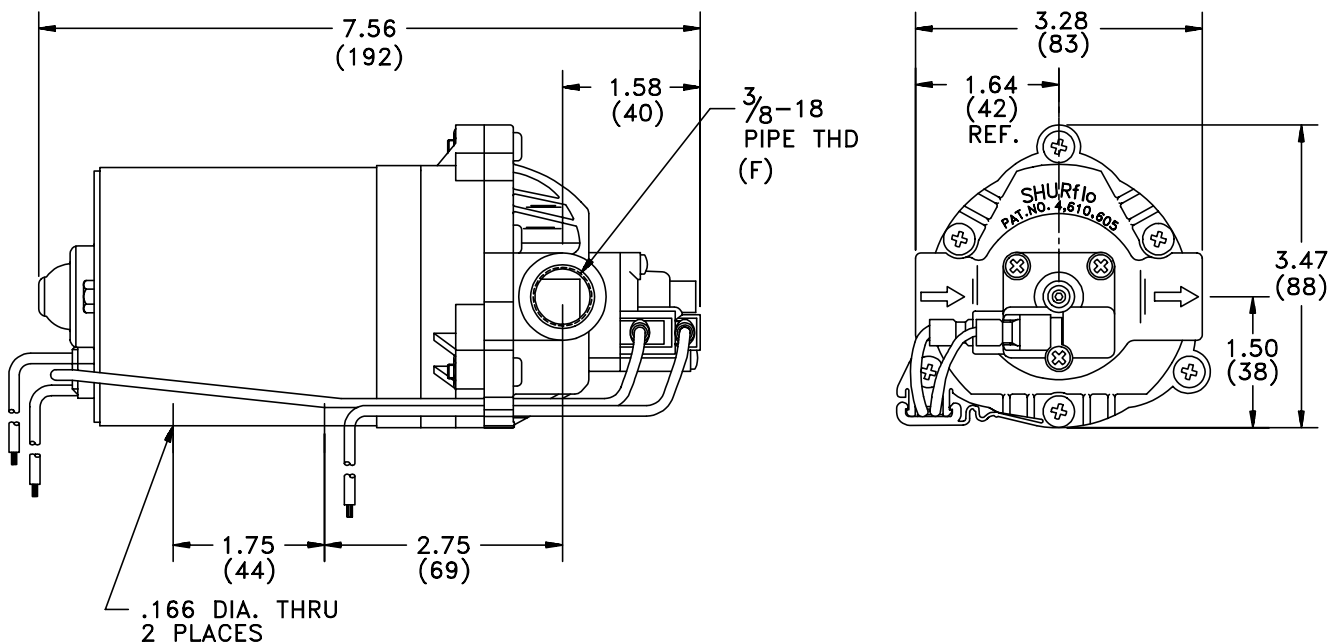

TEMPERATURE RISE

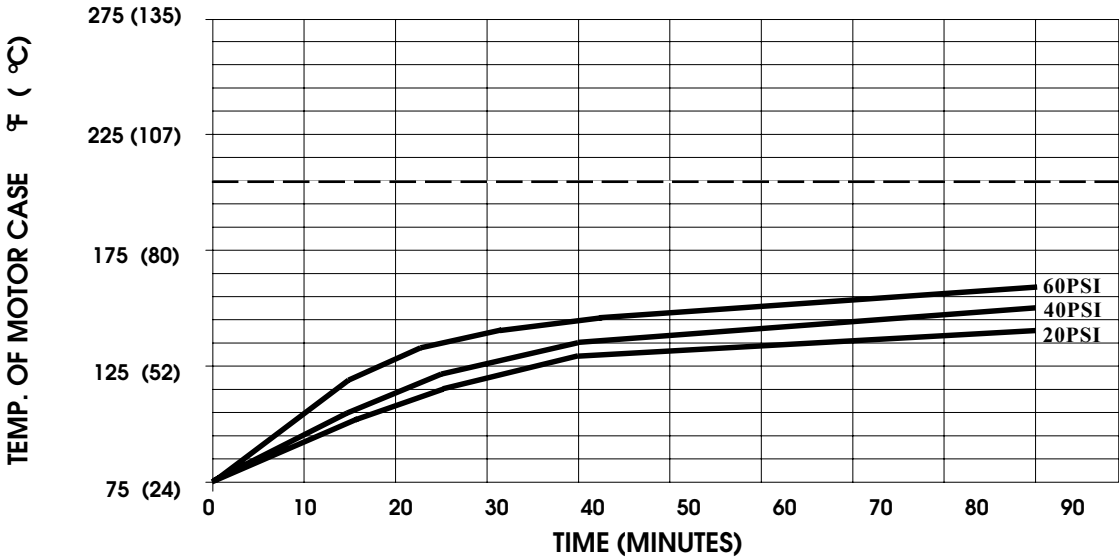

THIS GRAPH IS FOR USE AS A DESIGN GUIDE. IT IS BASED ON RUNNING CONTINUOUSLY WITH AN AMBIENT TEMPERATURE OF 75°F IN STILL AIR. THE THERMAL BREAKER WILL OPEN WHEN THE CASE TEMPERATURE REACHES 205° F.

[- - - - - TRIP POINT OF THERMAL PROTECTOR]

TYPICAL PERFORMANCE

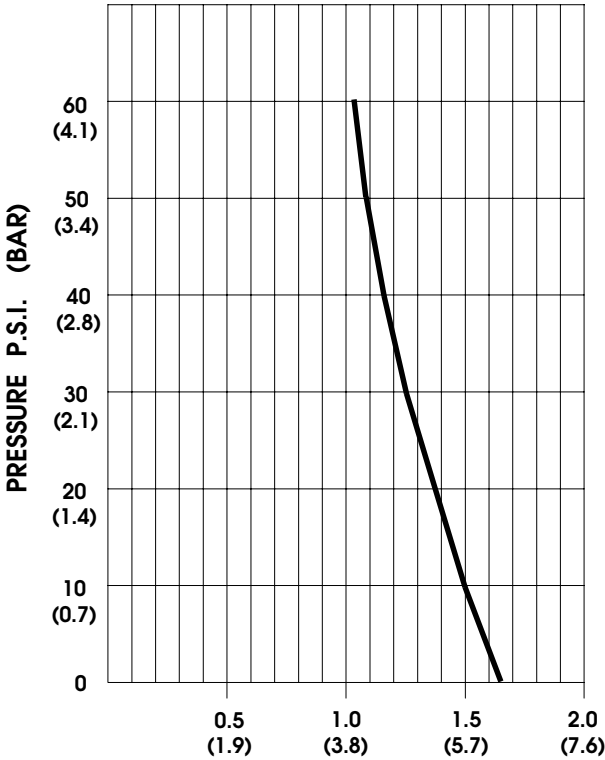

PRESSURE (PSI)	FLOW (GPM/LIT)	RPM MIN/MAX	CURRENT (AMPS)	VOLTAGE (VOLTS)
OPEN	1.64/6.2	2140/2160	0.31	115VAC
10	1.50/5.7	2015/2050	0.35	"
20	1.36/5.1	1900/1915	0.41	"
30	1.25/4.7	1770/1800	0.46	"
40	1.16/4.4	1655/1685	0.50	"
50	1.08/4.1	1565/1590	0.57	"
60	1.02/3.9	1510/1530	0.61	"

FLOW - GALLONS PER MINUTE (LITERS PER MINUTE)

*-SPECIFICATIONS SUBJECT TO CHANGE WITHOUT NOTICE.
-ALL DATA BASED ON TESTING WITH WATER AT AMBIENT TEMPERATURE.*