

SPECIFICATIONS:

MODEL NUMBER: 8000-643-938

PUMP DESIGN: Positive Displacement 3 Chamber Diaphragm Pump

CAM: 3.0 Degree

MOTOR: Permanent Magnet, P/N 11-111-00

VOLTAGE: 12VDC Nominal

PRESSURE SWITCH: Adjustable Shut-Off (Range 80-100 PSI)

Factory Set @100 PSI, Turn On 85 PSI + 5 PSI

LIQUID TEMPERATURE: 180 Degrees Fahrenheit (82 Degrees Centigrade) Max.

PRIME: Self-Priming Up To 12.0 Ft. Vertical,
Max. Inlet Pressure 30 PSI (2.1 Bar)

PORTS: 3/8"-18 NPT, Female

MATERIAL OF CONSTRUCTION:

PLASTICS- Nylon

VALVES- Buna-n

DIAPHRAGM- Geolast

FASTENERS- Zinc Plated Steel

NET WEIGHT: 4.6 Lbs (2.1 Kg)

DUTY CYCLE: Intermittent (See Temperature Rise Chart)

TYPICAL APPLICATIONS: Soil Extraction

DIMENSIONS:

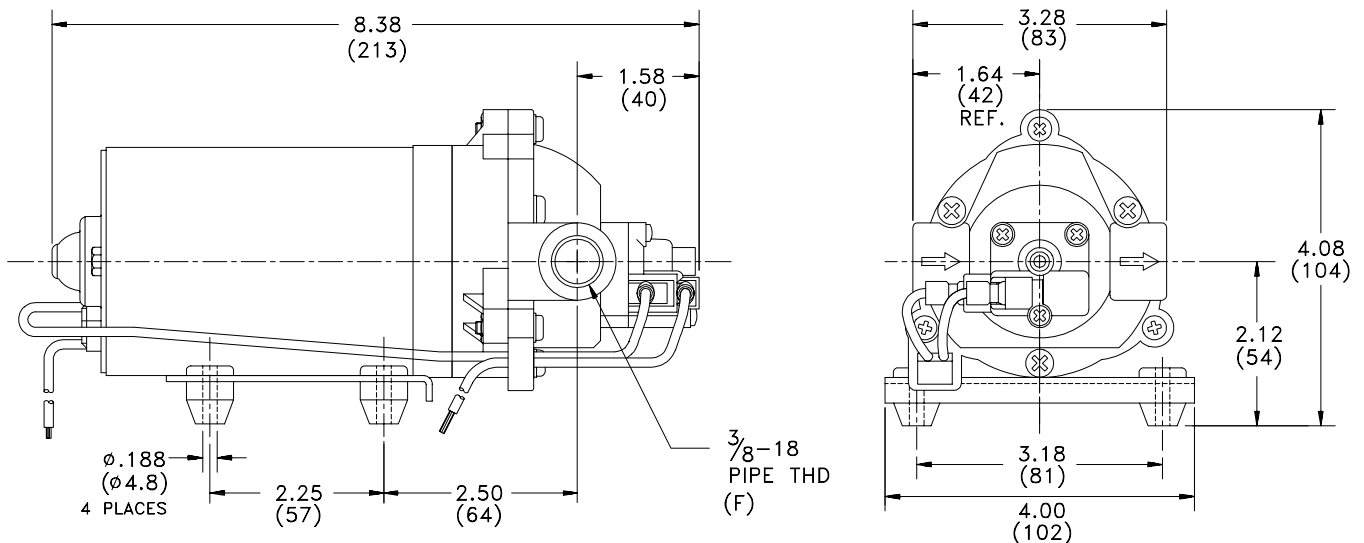

TEMPERATURE RISE

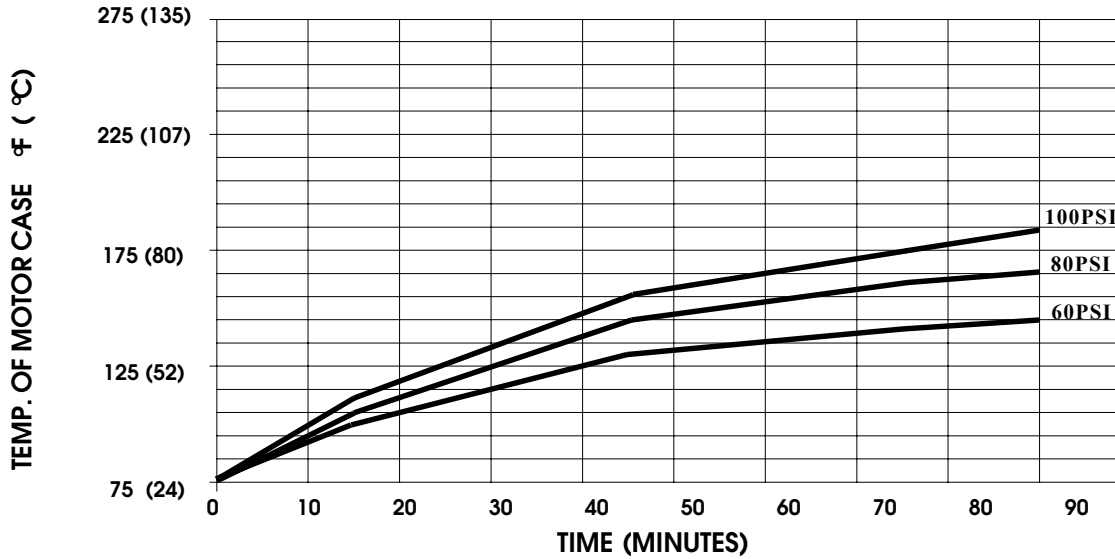

THIS GRAPH IS FOR USE AS A DESIGN GUIDE. IT IS BASED ON RUNNING CONTINUOUSLY WITH AN AMBIENT TEMPERATURE OF 75° F IN STILL AIR.

TYPICAL PERFORMANCE

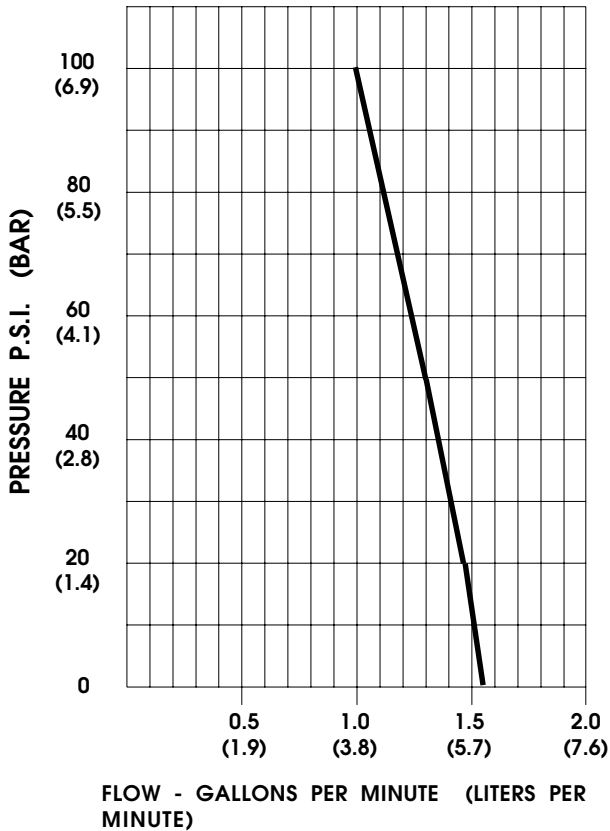

PRESSURE (PSI)	FLOW (GPM/LIT)	RPM MIN/MAX	CURRENT (AMPS)	VOLTAGE (VOLTS)
OPEN	1.55/5.9	2237/2276	3.2	24 VDC
10	1.53/5.8	2208/2245	3.6	"
20	1.48/5.6	2175/2210	4.2	"
30	1.41/5.3	2125/2180	4.9	"
40	1.36/5.1	2090/2130	5.5	"
50	1.30/4.9	2050/2080	6.0	"
60	1.24/4.7	2005/2045	6.7	"
70	1.19/4.5	1965/1990	7.3	"
80	1.14/4.3	1915/1955	7.9	"
90	1.09/4.1	1875/1910	8.5	"
100	1.00/3.8	1845/1860	9.0	"

*-SPECIFICATIONS SUBJECT TO CHANGE WITHOUT NOTICE.
-ALL DATA BASED ON TESTING WITH WATER AT AMBIENT TEMPERATURE.*