

SPECIFICATIONS:

- MODEL NUMBER:** 8000-553-890 (**Johnson Diversey**)
- PUMP DESIGN:** Positive Displacement 3 Chamber Diaphragm Pump
- CHECK VALVE:** (1-Way Operation) Prevents Reverse Flow
- CAM:** 3.0 Degree
- MOTOR:** Permanent Magnet, P/N 11-127-10
- VOLTAGE:** 24 VDC Nominal
- PRESSURE RATING:** No Control Do Not Exceed 100 PSI
- LIQUID TEMPERATURE:** 180 Degrees Fahrenheit (82 Degrees Centigrade) Max.
- PRIME:** Self-Priming Up To 9 Ft. Vertical,
 Max. Inlet Pressure 30 PSI (2.1 Bar)
- PORTS:** 1/2"-14 Male Parallel Thread
- MATERIAL OF CONSTRUCTION:**
 - PLASTICS-** Poly
 - VALVES-** Viton
 - DIAPHRAGM-** Santoprene
 - FASTENERS-** Zinc Plated Steel
- NET WEIGHT:** 4.7 Lbs (2.13 Kg)
- DUTY CYCLE:** Intermittent (See Temperature Rise Chart)

DIMENSIONS:

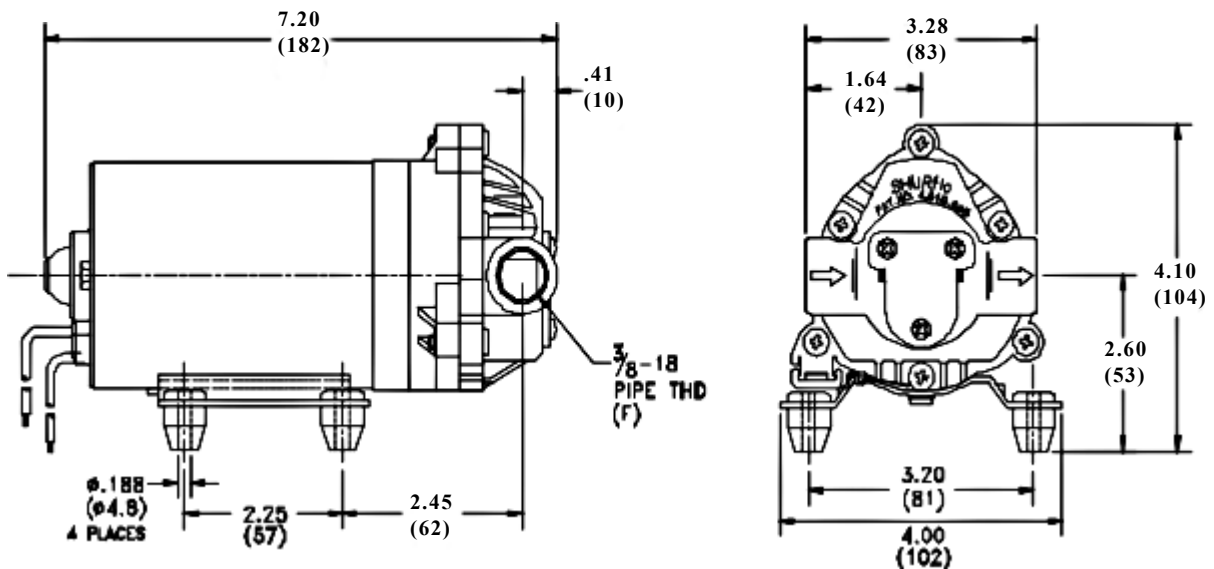

TEMPERATURE RISE

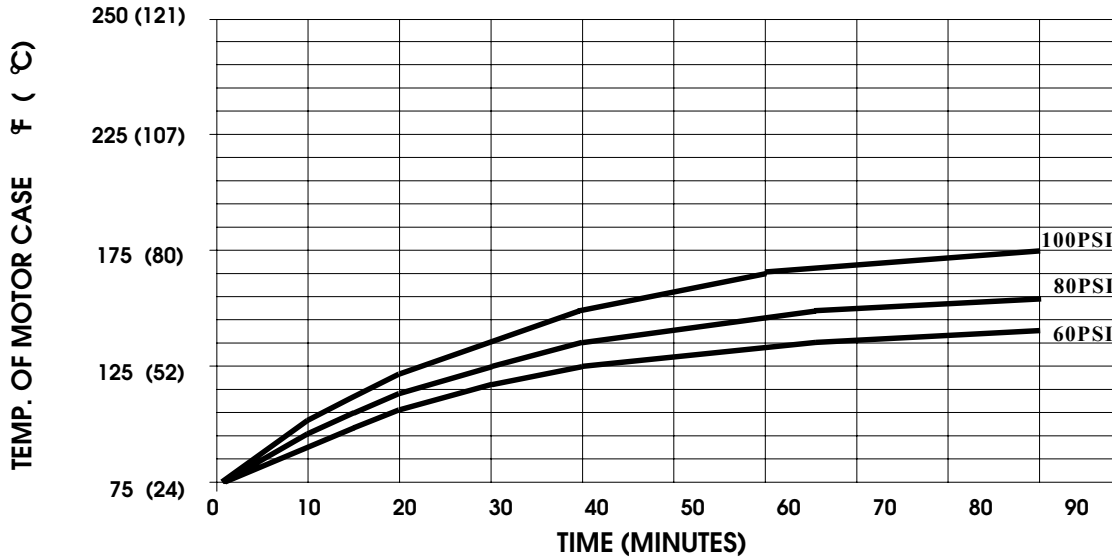

THIS GRAPH IS FOR USE AS A DESIGN GUIDE. IT IS BASED ON RUNNING CONTINUOUSLY WITH AN AMBIENT TEMPERATURE OF 70° F IN STILL AIR.

TYPICAL PERFORMANCE

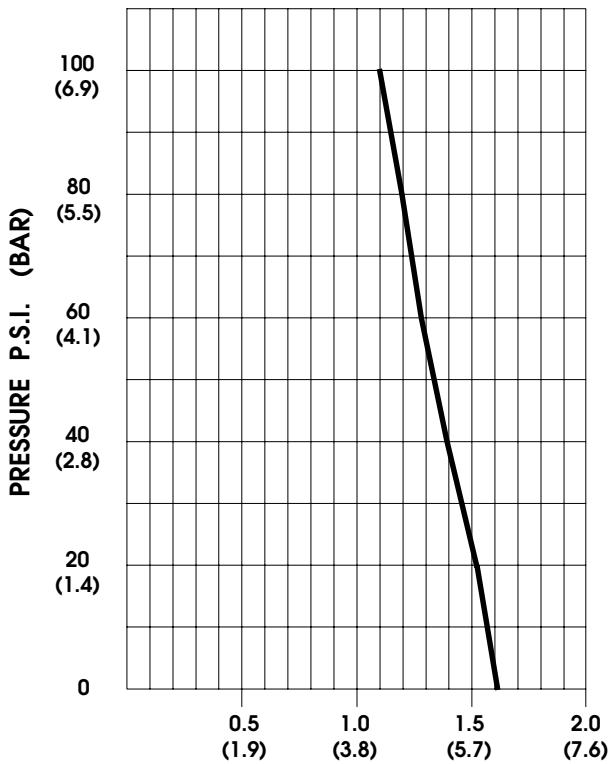

PRESSURE (PSI)	FLOW (GPM/LIT)	RPM MIN/MAX	CURRENT (AMPS)	VOLTAGE (VOLTS)
OPEN	1.58/6.0	2305/2320	1.8	24VDC
10	1.57/5.9	2280/2295	2.1	"
20	1.53/5.8	2240/2265	2.4	"
30	1.46/5.5	2200/2240	2.7	"
40	1.39/5.3	2145/2218	3.0	"
50	1.33/5.0	2115/2190	3.3	"
60	1.28/4.8	2090/2160	3.5	"
70	1.24/4.7	2065/2132	3.8	"
80	1.20/4.5	2030/2110	4.1	"
90	1.15/4.4	2000/2080	4.3	"
100	1.11/4.2	1970/2050	4.5	"

FLOW - GALLONS PER MINUTE (LITERS PER MINUTE)

*-SPECIFICATIONS SUBJECT TO CHANGE WITHOUT NOTICE.
-ALL DATA BASED ON TESTING WITH WATER AT AMBIENT TEMPERATURE.*