

**SPECIFICATIONS:**

- MODEL NUMBER:** 8000-542-136
- PUMP DESIGN:** Positive Displacement 3 Chamber Diaphragm Pump
- CHECK VALVE:** (1-Way Operation) Prevents Reverse Flow
- CAM:** 2.5 Degree
- MOTOR:** Permanent Magnet, P/N 11-111-00
- VOLTAGE:** 12 VDC Nominal
- PRESSURE SWITCH:** Adjustable Shut-Off (Range 40-60 PSI)  
 Factory Set @ 60 PSI, Turn On 45 PSI ± 5 PSI
- LIQUID TEMPERATURE:** 170 Degrees Fahrenheit (77 Degrees Centigrade) Max.
- PRIME:** Self-Priming Up To 10 Ft. Vertical,  
 Max. Inlet Pressure 30 PSI (2.1 Bar)
- PORTS:** 1/2"-14 Male Parallel Thread
- MATERIAL OF CONSTRUCTION:**
  - PLASTICS-** Polypropylene
  - VALVES-** Viton
  - DIAPHRAGM-** Santoprene
  - FASTENERS-** Zinc Plated Steel
- NET WEIGHT:** 4.1 Lbs (1.9 Kg)
- DUTY CYCLE:** Continuous (See Temperature Rise Chart)
- TYPICAL APPLICATIONS:** Agricultural Spraying

**DIMENSIONS:**

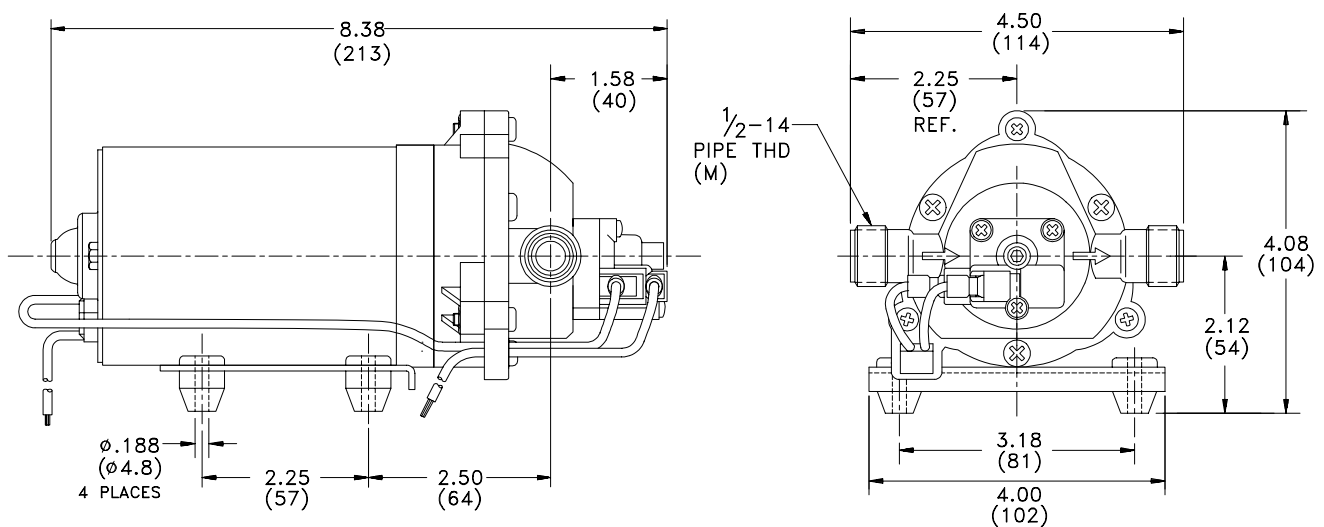

**TEMPERATURE RISE**

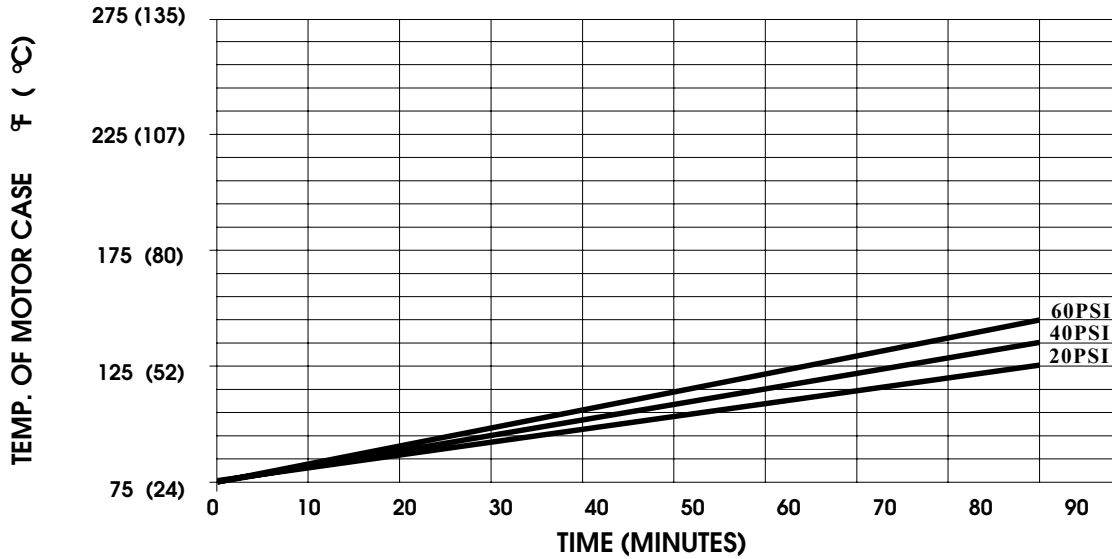

**TYPICAL PERFORMANCE**

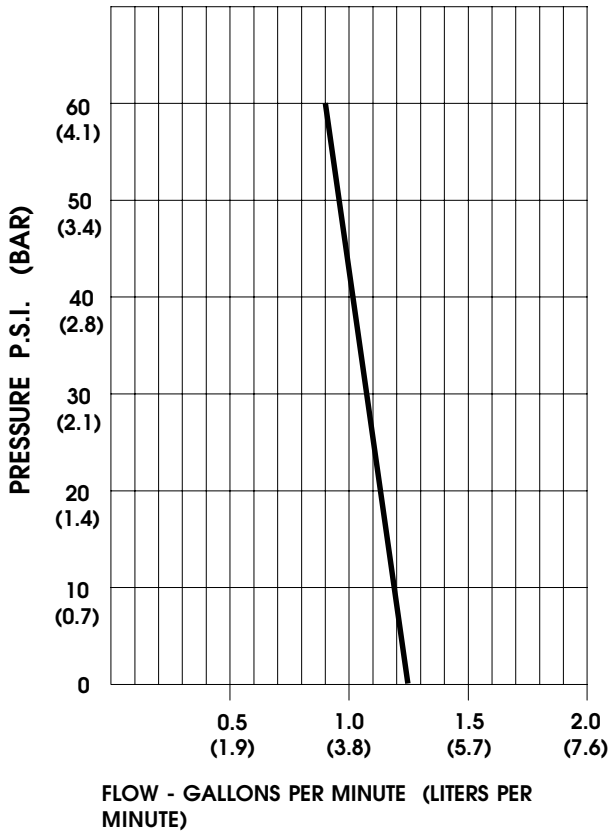

PRESSURE (PSI)	FLOW (GPM/LIT)	RPM MIN/MAX	CURRENT (AMPS)	VOLTAGE (VOLTS)
OPEN	1.23/4.6	2386/2408	3.1	12VDC
10	1.17/4.3	2327/2360	3.6	"
20	1.11/4.2	2298/2330	4.1	"
30	1.03/3.9	2256/2287	4.7	"
40	0.98/3.7	2228/2248	5.1	"
50	0.93/3.5	2193/2218	5.6	"
60	0.90/3.4	2154/2187	6.0	"

*-SPECIFICATIONS SUBJECT TO CHANGE WITHOUT NOTICE.*

*-ALL DATA BASED ON TESTING WITH WATER AT AMBIENT TEMPERATURE.*