

SPECIFICATIONS:

- MODEL NUMBER:** 8000-223-200
- PUMP DESIGN:** Positive Displacement 3 Chamber Diaphragm Pump
- CAM:** 3.0 Degree
- MOTOR:** Permanent Magnet, P/N 11-113-04, Thermally Protected
- VOLTAGE:** 115 VAC Nominal
- PRESSURE SWITCH:** None
- LIQUID TEMPERATURE:** 170 Degrees Fahrenheit (77 Degrees Centigrade) Max.
- PRIME:** Self-Priming Up To 12 Ft. Vertical,
Max. Inlet Pressure 30 PSI (2.1 Bar)
- PORTS:** 3/8"-18 NPT Female
- MATERIAL OF CONSTRUCTION:**
 - PLASTICS-** Polypropylene
 - VALVES-** EPDM
 - DIAPHRAGM-** Santoprene
 - FASTENERS-** Zinc Plated Steel
- NET WEIGHT:** 4.4 Lbs (2.0 Kg)
- DUTY CYCLE:** Intermittent (See Temperature Rise Chart)
- TYPICAL APPLICATIONS:** Flush Pump For Chemical Dispenser
- APPROVALS:** UL Recognized Component

DIMENSIONS:

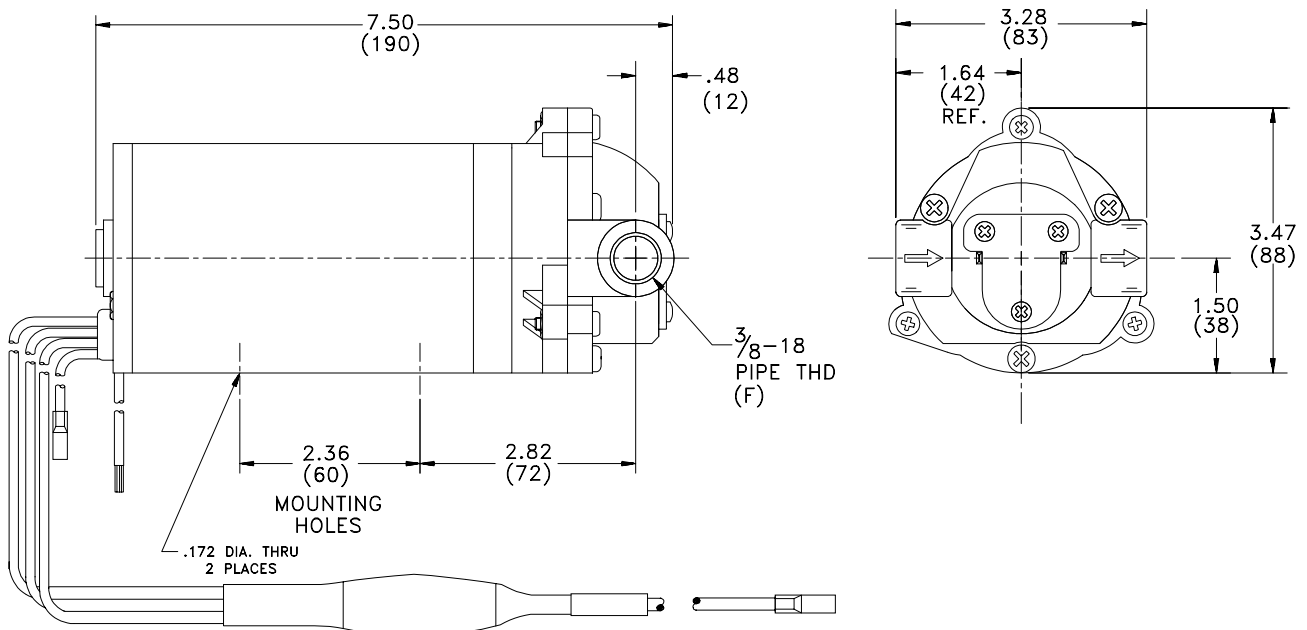

TEMPERATURE RISE

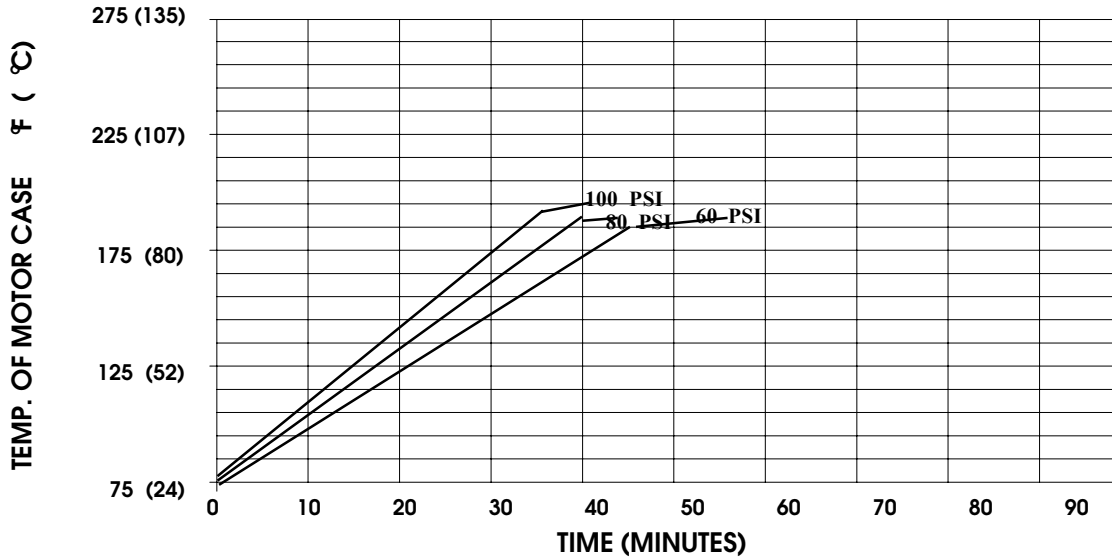

THIS GRAPH IS FOR USE AS A DESIGN GUIDE. IT IS BASED ON RUNNING CONTINUOUSLY WITH AN AMBIENT TEMPERATURE OF 70°F IN STILL AIR. THE THERMAL BREAKER WILL OPEN WHEN THE CASE TEMPERATURE REACHES 190° F.

[----- TRIP POINT OF THERMAL PROTECTOR]

TYPICAL PERFORMANCE

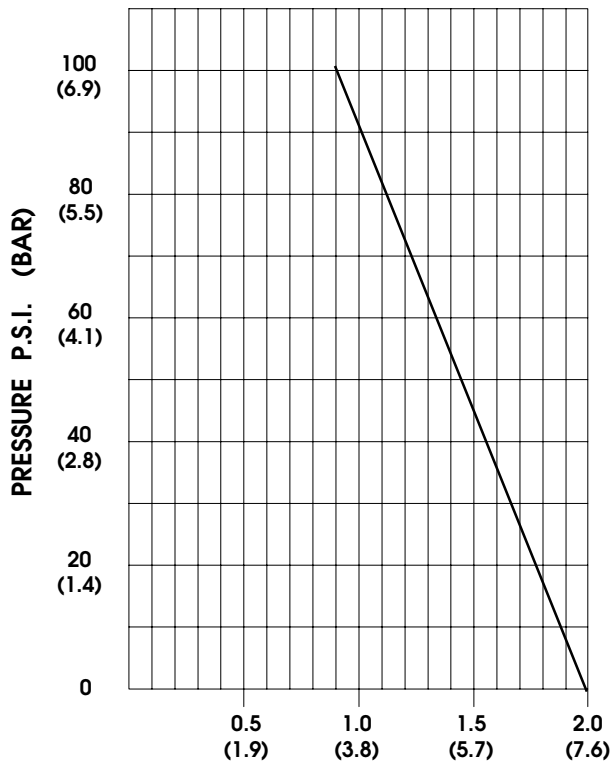

PRESSURE (PSI)	FLOW (GPM/LIT)	RPM MIN/MAX	CURRENT (AMPS)	VOLTAGE (VOLTS)
OPEN	1.85/7.0	2675/2750	0.71	115VAC
10	1.765/6.7	2595/2675	0.78	
20	1.67/6.3	2490/2560	0.85	
30	1.58/6.0	2380/2460	0.92	
40	1.49/5.6	2295/2360	0.99	
50	1.40/5.3	2215/2305	1.06	
60	1.31/4.9	2140/2235	1.10	
70	1.23/4.6	2070/2155	1.17	
80	1.16/4.4	2025/2075	1.22	
90	1.09/4.1	2005/2025	1.27	
100	1.02/3.9	1980/1990	1.31	

FLOW - GALLONS PER MINUTE (LITERS PER MINUTE)

-SPECIFICATIONS SUBJECT TO CHANGE WITHOUT NOTICE.

-ALL DATA BASED ON TESTING WITH WATER.