

SPECIFICATIONS:

MODEL NUMBER: 5904-1211

PUMP DESIGN: 5 Chamber Diaphragm

CAM: 3.5

MOTOR: Permanent Magnet, Intermittent Duty

MOTOR PROTECTION: Thermal Overload, Automatic Restart

VOLTAGE: 24 VDC

SHUT-OFF: Voltage Variant, Factory Set @ 60 PSI [3.1 Bar] \pm 5 PSI [0.4 Bar]

LIQUID TEMPERATURE: 130 F [54 C] Max

PRIME: 6 Feet [2.7 M]

PORTS: Quick Connect

MATERIAL OF CONSTRUCTION:

PLASTICS- Nylon

VALVES- EPDM

DIAPHRAGM- Santoprene

FASTENERS- Stainless Steel

NET WEIGHT: 8.5 Lbs.

DUTY CYCLE: Intermittent

TYPICAL APPLICATIONS: Solar

DIMENSIONS:

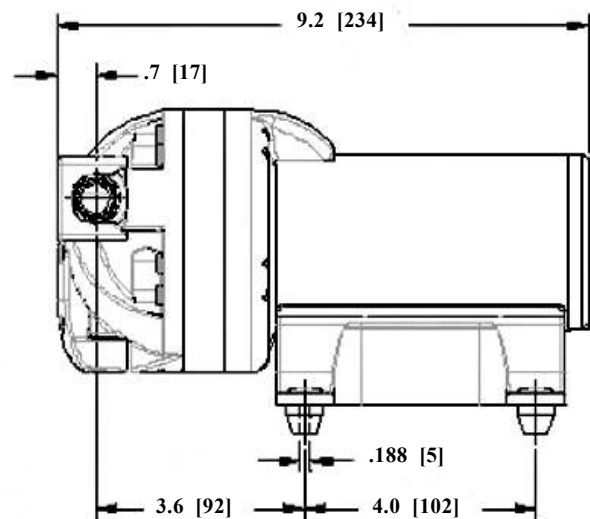
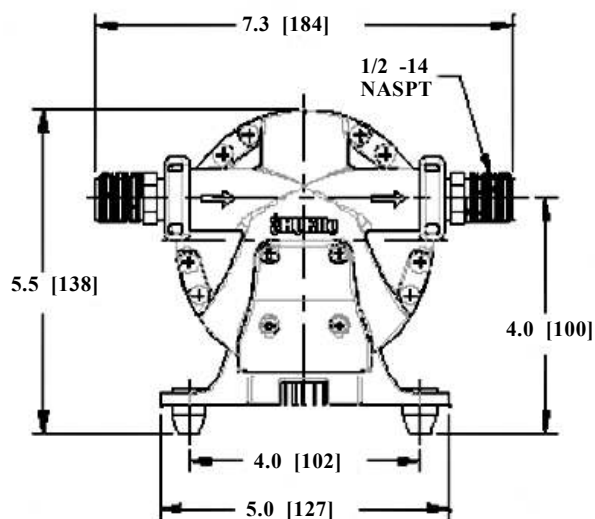

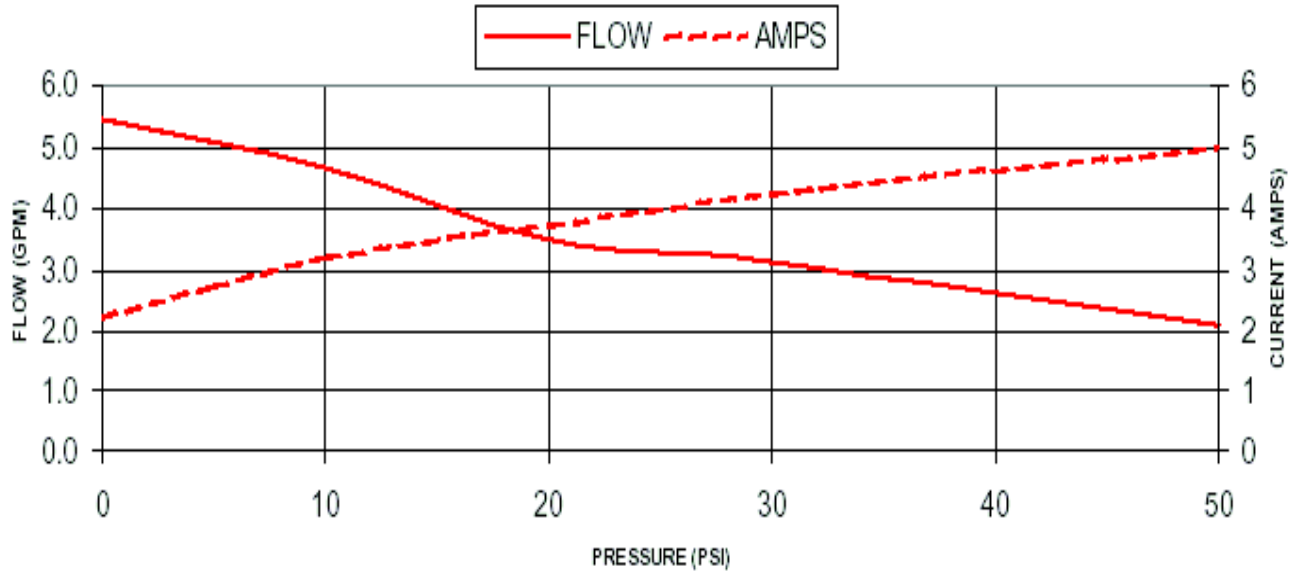

TYPICAL PERFORMANCE

PRESSURE		FLOW		CURRENT
BAR	PSI	GPM	LPM	AMPS
0.0	0	5.50	20.8	2.22
0.7	10	4.70	17.8	3.20
1.4	20	3.50	13.2	3.75
2.1	30	3.10	11.7	4.25
3.5	50	2.10	7.94	5.00

-SPECIFICATIONS SUBJECT TO CHANGE WITHOUT NOTICE.

-ALL DATA BASED ON TESTING WITH WATER AT AMBIENT TEMPERATURE.