

MARINE PRODUCT DATA SHEET

OEM 4901-2202
 AFTERMARKET 4901-2212



Wash-Down 4.0

TYPICAL APPLICATIONS

12 VDC pressurized water systems and wash down pump. For other applications, contact SHURflo.

PUMP

Type: 4 Chamber Diaphragm
 Ports: Quick Connect Fittings.
 Liquid: 130 °F [54 °C] Max
 Prime: 6 feet [1.82 M]
 Inlet PSI: 30 PSI [2.1 Bar] Max
 Run Dry: Yes

ELECTRICAL

Motor: 12VDC Permanent Magnet, Intermittent Duty
 Protection: Thermal Overload, Automatic Restart
 Leads: 14 AWG, 16" [40 cm] Red +, 13" [33 cm] Black -
 Fuse: 15 Amp Recommended
 Control: Adjustable Switch. Shut-Off 45 PSI [3.1 Bar] ± 5 PSI [0.4 Bar]
 Restart 25 PSI [1.8 Bar] ± 5 PSI [0.4 Bar]

MATERIALS

Housing: Nylon
 Valves: EPDM
 Diaphragm: Santoprene
 Hardware: Stainless Steel

APPROVALS

Ignition Protected, ISO 8846

WARRANTY

3 Year Limited Warranty
 See SB-1041 & SB-1050 For Full Warranty Details

SHIPPING

Net Weight (Boxed): Lb [Kg] each
 Carton Weight: each, Lb [Kg]
 Carton Size: "L x "W x "H [cm x cm x cm]

RELATED DOCUMENTS

Catalog: MS-030-084
 Installation Manual: 911-699
 Maintenance: 911-699
 Applications Spec Guide: MS-020-005
 Warranty: SB-1041 / SB-1050



Number	Components	Parts Kits
1	Housing / Switch	94-668-00
2	Valve Assembly	94-669-00
3	Drive Assembly	94-670-00
4	Motor	77-013-17



MARINE PRODUCT DATA SHEET

OEM 4901-2202
 AFTERMARKET 4901-2212



TYPICAL PERFORMANCE @ 12V DC

PRESSURE		FLOW		CURRENT
BAR	PSI	GPM	LPM	AMPS
0.0	0	4.0	15.1	4.1
0.7	10	3.3	12.5	6.3
1.4	20	2.9	10.1	7.6
2.1	30	2.7	10.2	8.8
2.8	40	2.4	9.0	10.0

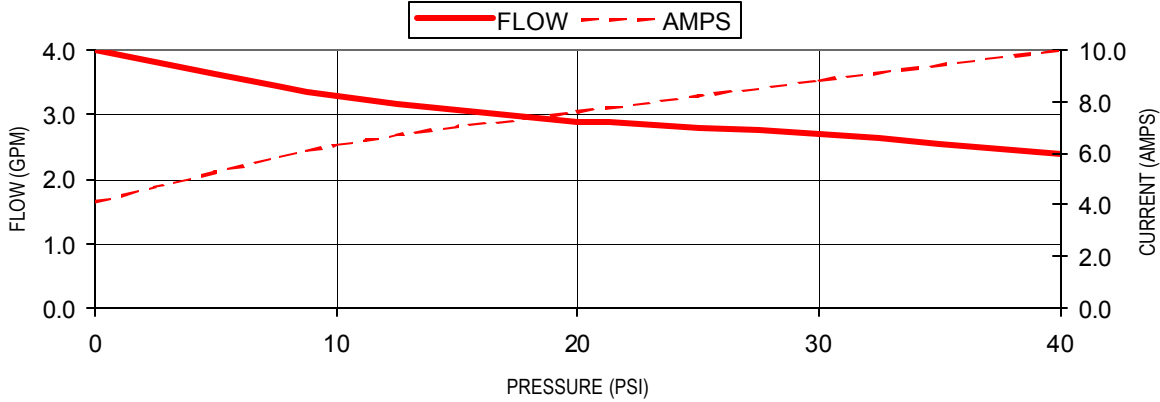

DIMENSIONS [mm]

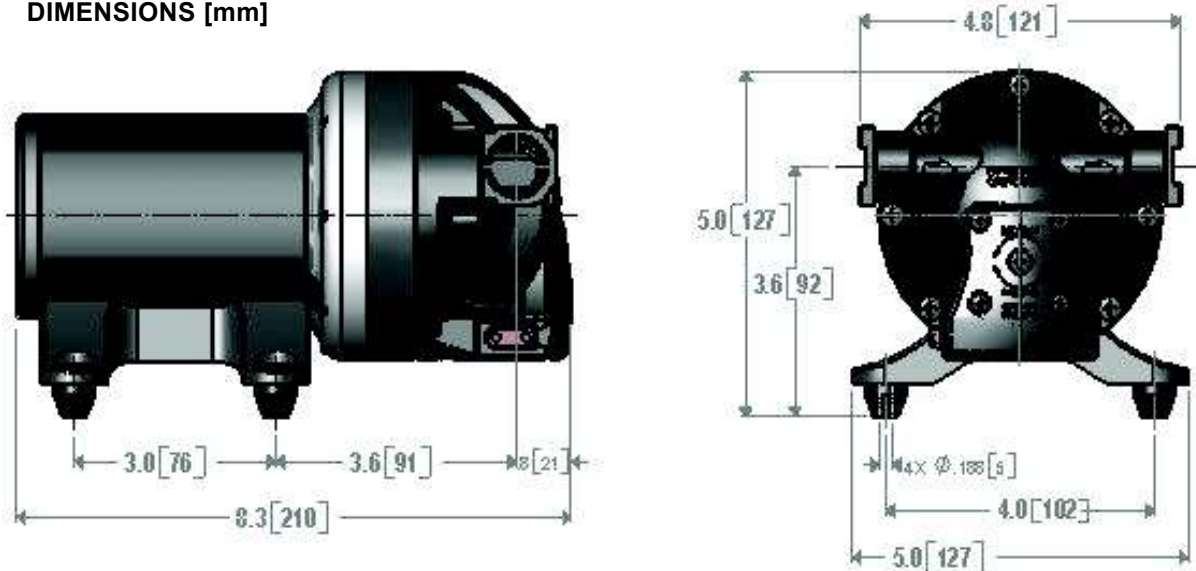

*ISO Registered Facility

SHURflo reserves the right to update specifications, prices, or make substitutions.

SHURflo *
 5900A Katella Ave.
 Cypress, Ca. 90630
 (800) 854-3218 (562) 795-5200
 FAX (562) 795-7554
 Shipping/UPS: 5900C Katella Ave.
 Cypress, Ca. 90630

SHURflo East
 52748 Park Six Court
 Elkhart, IN 46514-5427
 (800) 762-809 (574) 262-0478
 FAX (574) 264-2169
 Http://www.shurflo.com
 © 2001

SHURflo Ltd. *
 Unit 5 Sterling Park
 Gatwick Road, Crawley
 West Sussex, RH10 2QT
 United Kingdom
 +44 1293 424000
 FAX +44 1293 421880

