

# SHURflo

Depco  
Home



## MARINE PRODUCT DATA SHEET

**OEM: 358-010-00 (2000 GPH)**  
**AFTERMARKET: 358-010-10 (2000 GPH)**

Heavy duty and built to last. SHURflo's 1500 nylon bilge pump offer a unique motor cooling system (patent pending) to ensure efficient performance and long life. Installation is a snap with our patented swivel base and 6' tinned wire assembly.

### TYPICAL APPLICATIONS

12V Marine Bilge Water Evacuation. For other applications, Contact SHURflo.

### PUMP

Type: Centrifugal Pump  
Port: 1 1/8" Barb  
Liquid: 130 °F [54 °C] Max  
Prime: Flooded Inlet  
Inlet PSI: N/A  
Run Dry: No

### ELECTRICAL

Motor: 12VDC Permanent Magnet, Continuous Duty  
Protection: External Fuse  
Leads: 6 ft (1.8M) Tinned, 16 AWG  
Fuse: 15 Amp Recommended  
Control: No Control

### MATERIALS

Housing: High Strength Nylon  
Impeller: High Strength Nylon  
Hardware: Stainless Steel

### APPROVALS

Ignition Protected, CE, ISO 8846

### WARRANTY

3 Year Limited Warranty  
See SB-1050 For Full Warranty Details

### SHIPPING

Net Weight (Boxed): Lb ( Kg) each  
Carton Weight: Lb [ Kg]  
Pumps in Carton: 8  
Carton Size: "L x "W x " H [cm x cm x cm]

### RELATED DOCUMENTS

Catalog: MS-030-140  
Installation Manual: 911-742-00  
Maintenance: 911-742-00  
Applications Spec Guide: MS-020-005  
Warranty: SB-1050

### Replacement Kit

94-007-01



PERFORMANCE @ 13.6V DC

PRESSURE		FLOW		CURRENT
METERS	FT OF HEAD	GPH	LPH	AMPS
0.0	0	2200	8327	10.5
1.20	4	1950	7380	10.2
2.40	8	1800	6813	10

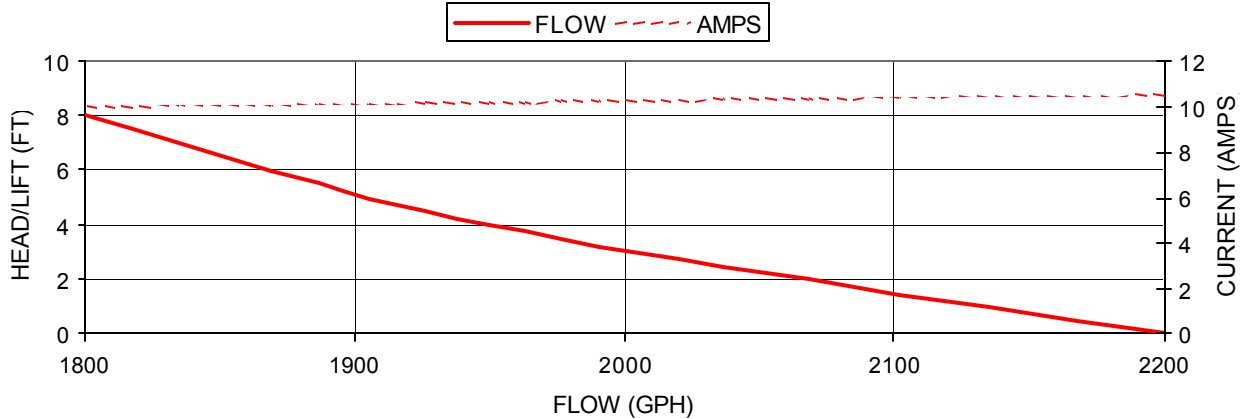

DIMENSIONS [mm]

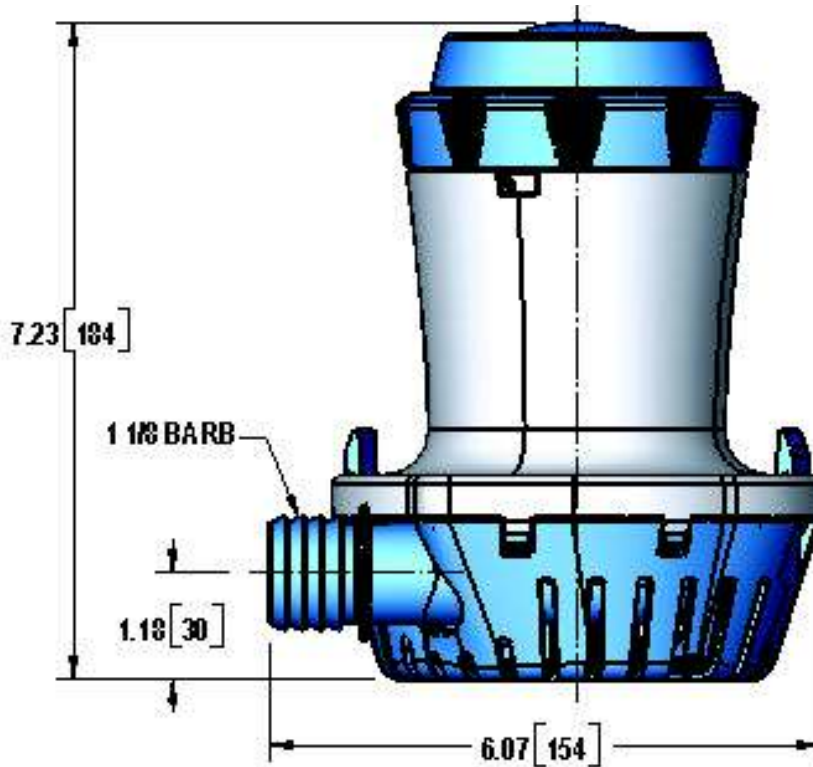

\*ISO Registered Facility SHURflo reserves the right to update specifications, prices, or make substitutions.

SHURflo \*  
 5900A Katella Ave.  
 Cypress, Ca. 90630  
 (800) 854-3218 (562) 795-5200  
 FAX (562) 795-7554  
 Shipping/UPS: 5900C Katella Ave.  
 Cypress, Ca. 90630

SHURflo East  
 52748 Park Six Court  
 Elkhart, IN 46514-5427  
 (800) 762-809 (574) 262-0478  
 FAX (574) 264-2169  
 Http://www.shurflo.com  
 © 2001

SHURflo Ltd. \*  
 Unit 5 Sterling Park  
 Gatwick Road, Crawley  
 West Sussex, RH10 2QT  
 United Kingdom  
 +44 1293 424000  
 FAX +44 1293 421880

