

SHURflo



MARINE PRODUCT DATA SHEET

OEM: 358-000-00 (1500 GPH)
AFTERMARKET: 358-000-10 (1500 GPH)

Heavy duty and built to last. SHURflo's 1500 nylon bilge pump offer a unique motor cooling system (patent pending) to ensure efficient performance and long life. Installation is a snap with our patented swivel base and 6' tinned wire assembly.

TYPICAL APPLICATIONS

12V Marine Bilge Water Evacuation. For other applications, Contact SHURflo.

PUMP

Type: Centrifugal Pump
Port: 1 1/8" Barb
Liquid: 130 °F [54 °C] Max
Prime: Flooded Inlet
Inlet PSI: N/A
Run Dry: No

ELECTRICAL

Motor: 12VDC Permanent Magnet, Continuous Duty
Protection: External Fuse
Leads: 6 ft (1.8M) Tinned, 16 AWG
Fuse: 10 Amp Recommended
Control: No Control

MATERIALS

Housing: High Strength Nylon
Impeller: High Strength Nylon
Hardware: Stainless Steel

APPROVALS

Ignition Protected, CE, ISO 8846

WARRANTY

3 Year Limited Warranty
See SB-1050 For Full Warranty Details

SHIPPING

Net Weight (Boxed): Lb (Kg) each
Carton Weight: Lb [13.6 Kg]
Pumps in Carton: 8
Carton Size: "L x "W x " H [cm x cm x cm]

RELATED DOCUMENTS

Catalog: MS-030-140
Installation Manual: 911-742
Maintenance: 911-742
Applications Spec Guide: MS-020-005
Warranty: SB-1050

Replacement Kit

94-007-01



PERFORMANCE @ 13.6V DC

PRESSURE		FLOW		CURRENT
METERS	FT OF HEAD	GPH	LPH	AMPS
0.0	0	1800	6813	7.75
1.20	4	1650	6442	7.5
2.40	8	1400	5299	7.0

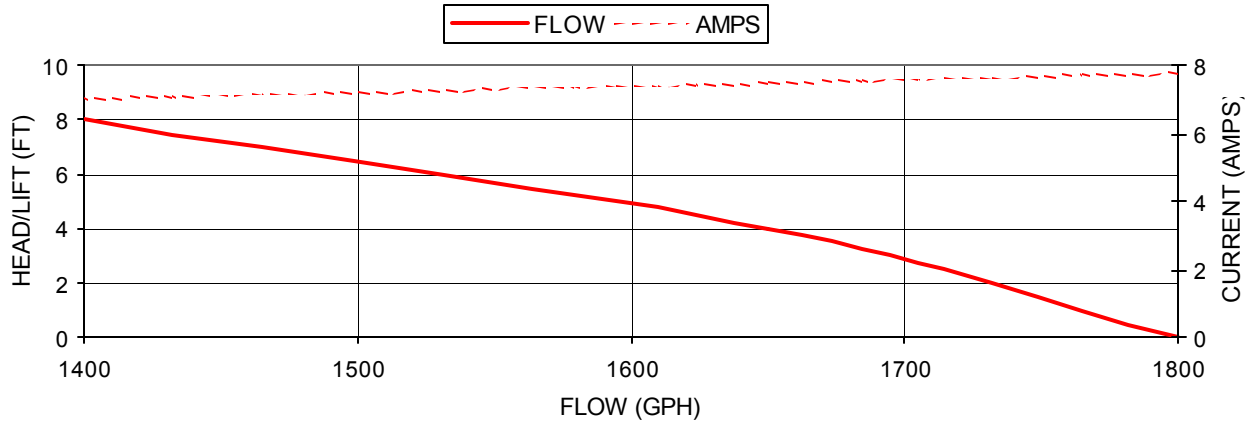

DIMENSIONS [mm]

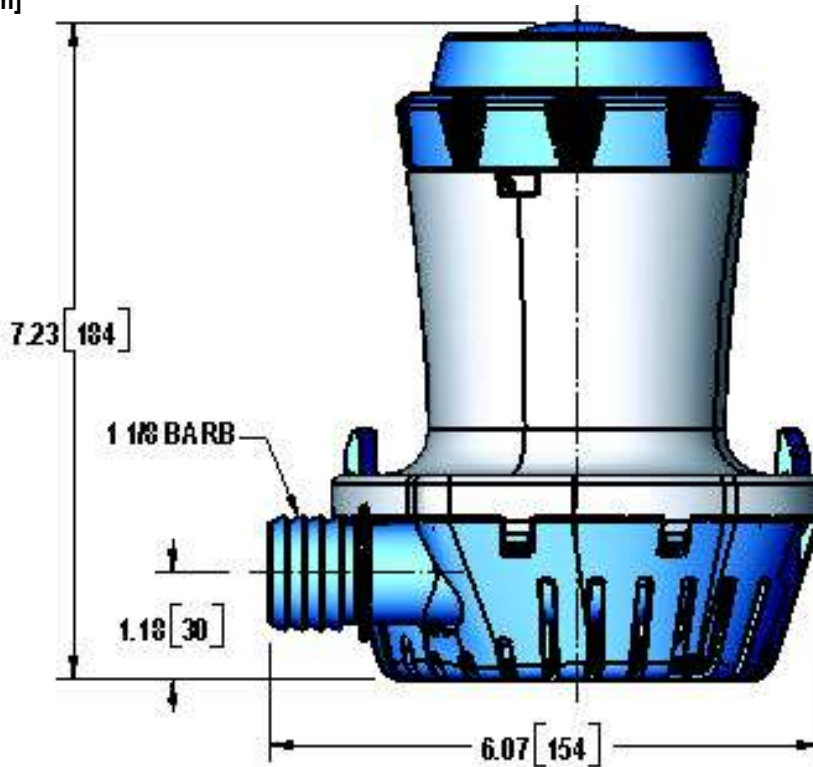

*ISO Registered Facility SHURflo reserves the right to update specifications, prices, or make substitutions.

SHURflo *
5900A Katella Ave.
Cypress, Ca. 90630
(800) 854-3218 (562) 795-5200
FAX (562) 795-7554
Shipping/UPS: 5900C Katella Ave.
Cypress, Ca. 90630

SHURflo East
52748 Park Six Court
Elkhart, IN 46514-5427
(800) 762-809 (574) 262-0478
FAX (574) 264-2169
Http://www.shurflo.com
© 2001

SHURflo Ltd. *
Unit 5 Sterling Park
Gatwick Road, Crawley
West Sussex, RH10 2QT
United Kingdom
+44 1293 424000
FAX +44 1293 421880

