



## MARINE PRODUCT DATA SHEET

**OEM: 357-104-00 (1100 GPH)**  
**AFTERMARKET: 357-104-10 (1100 GPH)**

Everything you are looking for in an aerator pump. Our tough, high density nylon housing and heavy duty water cooled motor give the SHURflo Aerator Pumps unparalleled reliability. Patented anti-airlock feature allows the pump to clear trapped air in rough water or when the boat is anchored. All Piranha Series Aerator Pumps have a removable cartridge for easy cleaning.

### TYPICAL APPLICATIONS

12V DC Bait/Livewell Application. For other applications, contact SHURflo.

### PUMP

Type: Centrifugal Pump  
Output Port: 1 1/8" Barb  
Intake Port: 3/4" NPS-M  
Liquid: 130 °F [54 °C] Max  
Prime: Flooded Inlet  
Inlet PSI: 30 PSI [2.1 Bar] Max  
Run Dry: No

### ELECTRICAL

Motor: 12VDC Permanent Magnet, Continuous Duty  
Protection: External Fuse  
Leads: 6 ft (1.8M) Tinned, 16 AWG  
Fuse: 6 Amp Recommended  
Control: No Control

### MATERIALS

Housing: High Strength Nylon  
Impeller: High Strength Nylon  
Hardware: Stainless Steel

### APPROVALS

Ignition Protected, CE, ISO 8846

### WARRANTY

2 Year Limited Warranty  
See SB-1050 For Full Warranty Details

### SHIPPING

Net Weight (Boxed): 1.5 Lb (0.68 Kg) each  
Carton Weight: 27 Lb [12.2 Kg]  
Pumps in Carton: 18  
Carton Size: 24"L x 18"W x 11" H [61 cm x 46 cm x 28 cm]

### RELATED DOCUMENTS

Catalog: MS-030-140  
Installation Manual: 911-611-00  
Maintenance: 911-611-00  
Applications Spec Guide: MS-020-005  
Warranty: SB-1050

### Replacement Kit

94-620-00



**PERFORMANCE @ 13.6V DC**

PRESSURE		FLOW		CURRENT
METERS	FT OF HEAD	GPH	LPH	AMPS
0.0	0	1014	3837	4.60
2.4	8	330	1249	3.64
3.9	13	0.0	0.0	3.15

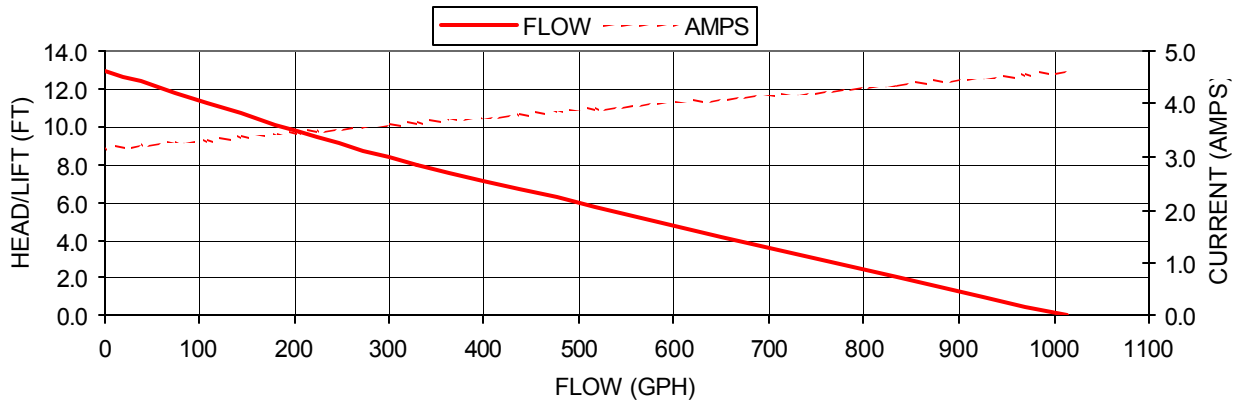

**DIMENSIONS [mm]**

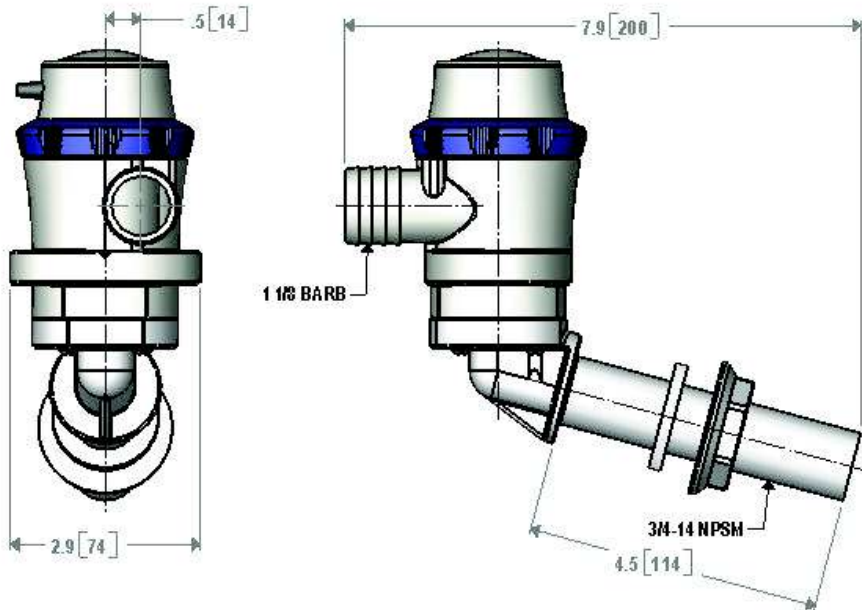

\*ISO Registered Facility

*SHURflo reserves the right to update specifications, prices, or make substitutions.*



**SHURflo \***  
 5900A Katella Ave.  
 Cypress, Ca. 90630  
 (800) 854-3218 (562) 795-5200  
 FAX (562) 795-7554  
 Shipping/UPS: 5900C Katella Ave.  
 Cypress, Ca. 90630

**SHURflo East**  
 52748 Park Six Court  
 Elkhart, IN 46514-5427  
 (800) 762-809 (574) 262-0478  
 FAX (574) 264-2169  
 Http://www.shurflo.com  
 © 2001

**SHURflo Ltd. \***  
 Unit 5 Sterling Park  
 Gatwick Road, Crawley  
 West Sussex, RH10 2QT  
 United Kingdom  
 +44 1293 424000  
 FAX +44 1293 421880