



MARINE PRODUCT DATA SHEET

OEM: 357-101-01 (1000 GPH)
AFTERMARKET: 357-101-11 (1000 GPH)

For a complete package combined the Piranha Series Bilge pumps with our reliable automatic float switch. Our tough, high density nylon housing and heavy duty water cooled motor gives the SHURflo Bilge Pump unparalleled reliability. Adding our non-mercury, solid state controlled switch with 2 second time delay ensures easy removal of water from the bilge. Easy Installation and removable cartridge for easy cleaning.

TYPICAL APPLICATIONS

12V Marine Bilge Water Evacuation. For other applications, contact SHURflo.

PUMP

Type: Centrifugal Pump
Port: 1 1/8" Barb
Liquid: 130 °F [54 °C] Max
Prime: Flooded Inlet
Run Dry: No

ELECTRICAL

Motor: 12VDC Permanent Magnet, Continuous Duty
Protection: External Fuse
Leads: 6 ft (1.8M) Tinned, 16 AWG
Fuse: 6 Amp Recommended
Control: Solid State Control with two second time delay, engaging only when water is in the bilge.

MATERIALS

Housing: High Strength Nylon
Impeller: High Strength Nylon
Hardware: Stainless Steel

APPROVALS

Ignition Protected, CE, ISO 8846

WARRANTY

3 Year Limited Warranty
See SB-1050 For Full Warranty Details

SHIPPING

Net Weight (Boxed): 1.25 Lb (0.56 Kg) each
Carton Weight: 30 Lb [13.6 Kg]
Pumps in Carton: 24
Carton Size: 24"L x 18"W x 11" H [61 cm x 46 cm x 28 cm]

RELATED DOCUMENTS

Catalog: MS-030-140
Installation Manual: 911-593-00
Maintenance: 911-593-00
Applications Spec Guide: MS-020-005
Warranty: SB-1050

Replacement Kits

94-006-00



94-007-00



PERFORMANCE @ 13.6V DC

PRESSURE		FLOW		CURRENT
METERS	FT OF HEAD	GPH	LPH	AMPS
0.0	0	1020	3860	4.14
1.20	4	777	2940	4.07
2.40	8	532	2013	3.90

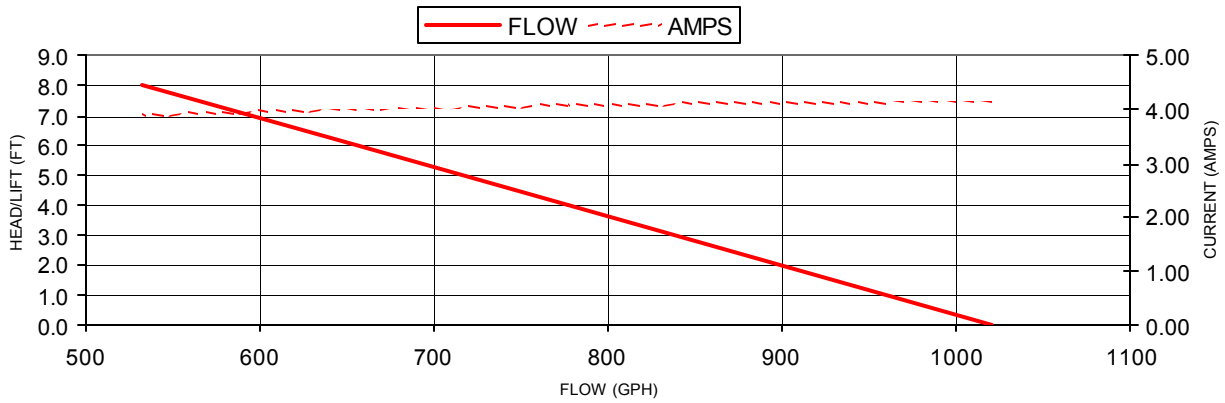

DIMENSIONS [mm]

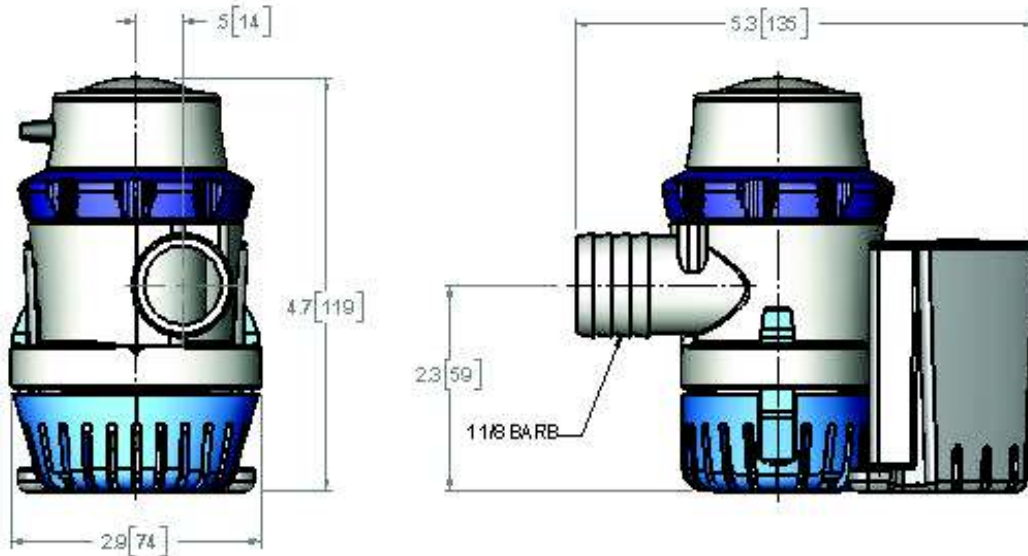

*ISO Registered Facility

SHURflo reserves the right to update specifications, prices, or make substitutions.



SHURflo *
 5900A Katella Ave.
 Cypress, Ca. 90630
 (800) 854-3218 (562) 795-5200
 FAX (562) 795-7554
 Shipping/UPS: 5900C Katella Ave.
 Cypress, Ca. 90630

SHURflo East
 52748 Park Six Court
 Elkhart, IN 46514-5427
 (800) 762-809 (574) 262-0478
 FAX (574) 264-2169
 Http://www.shurflo.com
 © 2001

SHURflo Ltd. *
 Unit 5 Sterling Park
 Gatwick Road, Crawley
 West Sussex, RH10 2QT
 United Kingdom
 +44 1293 424000
 FAX +44 1293 421880