

# SHURflo®



## **MARINE** PRODUCT DATA SHEET

**OEM: 355-020-00 (380 GPH)**  
**AFTERMARKET: 355-020-10 (380 GPH)**

Quality bilge pumps you can trust. SHURflo bilge pumps are built for the harsh marine environment to withstand the toughest conditions. Standard with 3' Tinned Wire Assembly for above waterline installations and water cooled motors for extended life.

### TYPICAL APPLICATIONS

12V Marine Bilge Water Evacuation. For other applications, Contact SHURflo.

### PUMP

Type: Centrifugal Pump  
Port: 3/4" Barb  
Liquid: 130 °F [54 °C] Max  
Prime: Flooded Inlet  
Run Dry: No

### ELECTRICAL

Motor: 12VDC Permanent Magnet, Continuous Duty  
Protection: External Fuse  
Leads: 3 ft (0.9M) Tinned, 16 AWG  
Fuse: 2.5 Amp Recommended  
Control: No Control

### MATERIALS

Housing: ABS  
Impeller: High Strength Nylon  
Hardware: Stainless Steel

### APPROVALS

Ignition Protected, CE, ISO 8846

### WARRANTY

3 Year Limited Warranty  
See SB-1050 For Full Warranty Details

### SHIPPING

Net Weight (Boxed): 1.25 Lb (0.56 Kg) each  
Carton Weight: 30 Lb [13.6 Kg]  
Pumps in Carton: 24  
Carton Size: 24"L x 18"W x 11" H [61 cm x 46 cm x 28 cm]

### RELATED DOCUMENTS

Catalog: MS-030-140  
Installation Manual: 911-758-00  
Maintenance: 911-758-00  
Applications Spec Guide: MS-020-005  
Warranty: SB-1050

### Replacement Kits

94-750-00



PERFORMANCE @ 13.6V DC

PRESSURE		FLOW		CURRENT
METERS	FT OF HEAD	GPH	LPH	AMPS
0.0	0	424	1604	1.96
1.20	4	303	1146	1.82
2.40	8	147	556	1.60

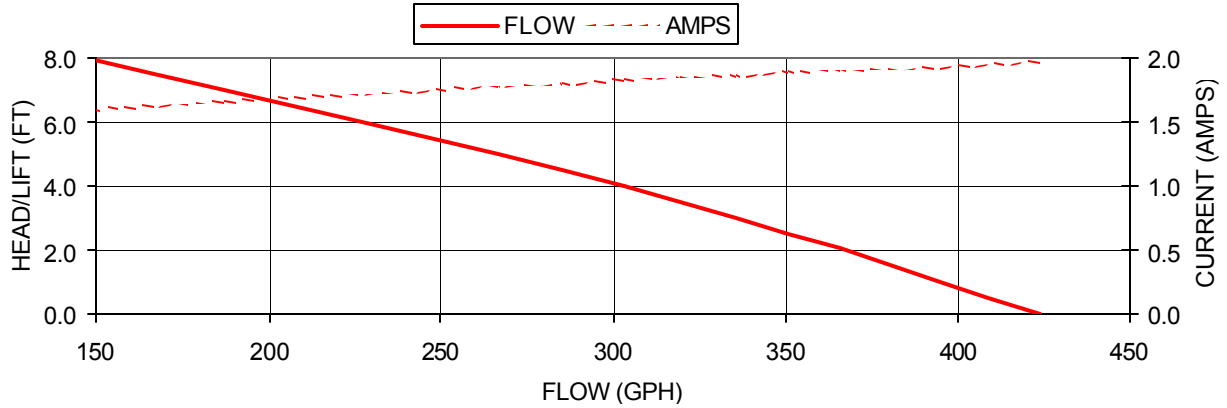

DIMENSIONS [mm]

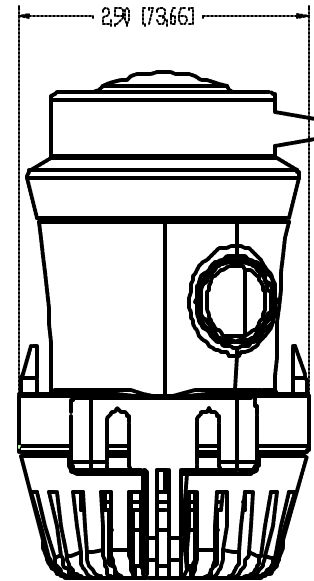
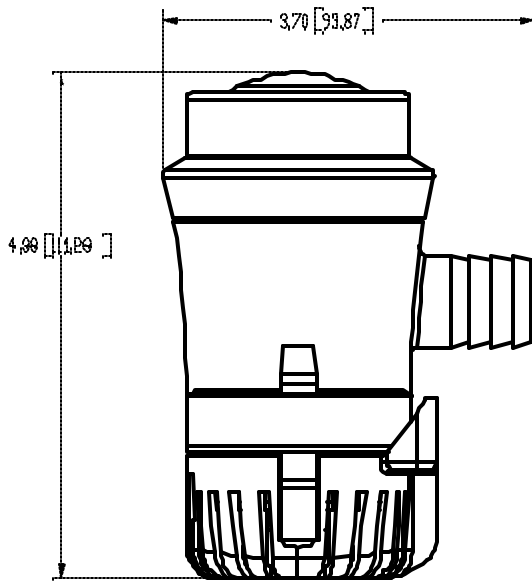

\*ISO Registered Facility

SHURflo reserves the right to update specifications, prices, or make substitutions.

SHURflo \*  
 5900A Katella Ave.  
 Cypress, Ca. 90630  
 (800) 854-3218 (562) 795-5200  
 FAX (562) 795-7554  
 Shipping/UPS: 5900C Katella Ave.  
 Cypress, Ca. 90630

SHURflo East  
 52748 Park Six Court  
 Elkhart, IN 46514-5427  
 (800) 762-809 (574) 262-0478  
 FAX (574) 264-2169  
 Http://www.shurflo.com  
 © 2001



SHURflo Ltd. \*  
 Unit 5 Sterling Park  
 Gatwick Road, Crawley  
 West Sussex, RH10 2QT  
 United Kingdom  
 +44 1293 424000  
 FAX +44 1293 421880