

SHURflo®



MARINE PRODUCT DATA SHEET

OEM: 355-010-00 (500 GPH)
AFTERMARKET: 355-010-10 (500 GPH)

Quality bilge pumps you can trust. SHURflo bilge pumps are built for the harsh marine environment to withstand the toughest conditions. Standard with 3' Tinned Wire Assembly for above waterline installations and water cooled motors for extended life.

TYPICAL APPLICATIONS

12V Marine Bilge Water Evacuation. For other applications, Contact SHURflo.

PUMP

Type: Centrifugal Pump
Port: 3/4" Barb
Liquid: 130 °F [54 °C] Max
Prime: Flooded Inlet
Run Dry: No

ELECTRICAL

Motor: 12VDC Permanent Magnet, Continuous Duty
Protection: External Fuse (Not supplied)
Leads: 3 ft [0.9M] Tinned, 16 AWG
Fuse: 2.5 Amp Recommended
Control: No Control

MATERIALS

Housing: ABS
Impeller: High Strength Nylon
Hardware: Stainless Steel

APPROVALS

Ignition Protected, CE, ISO 8846

WARRANTY

3 Year Limited Warranty
See SB-1050 For Full Warranty Details

SHIPPING

Net Weight (Boxed): 1.25 Lb [0.56 Kg] each
Carton Weight: 30 Lb [13.6 Kg]
Pumps in Carton: 24
Carton Size: 24"L x 18"W x 11" H [61cm x 46 cm x 28 cm]

RELATED DOCUMENTS

Catalog: MS-030-140
Installation Manual: 911-758-00
Maintenance: 911-758-00
Applications Spec Guide: MS-020-005
Warranty: SB-1050

94-750-00



PERFORMANCE @ 13.6V DC

PRESSURE		FLOW		CURRENT
METERS	FT OF HEAD	GPH	LPH	AMPS
0.0	0	582	2202	2.06
1.2	4	476	1801	2.05
2.4	8	182	688	1.69

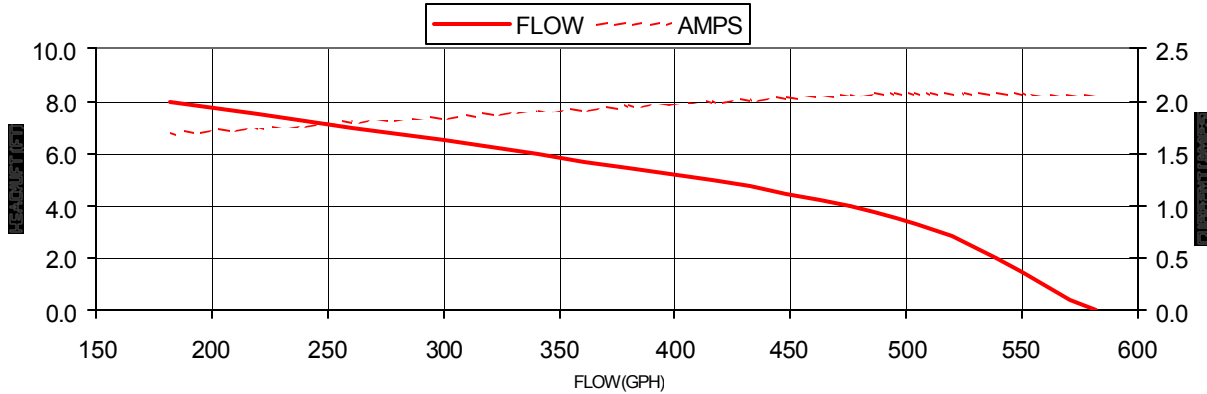

DIMENSIONS [mm]

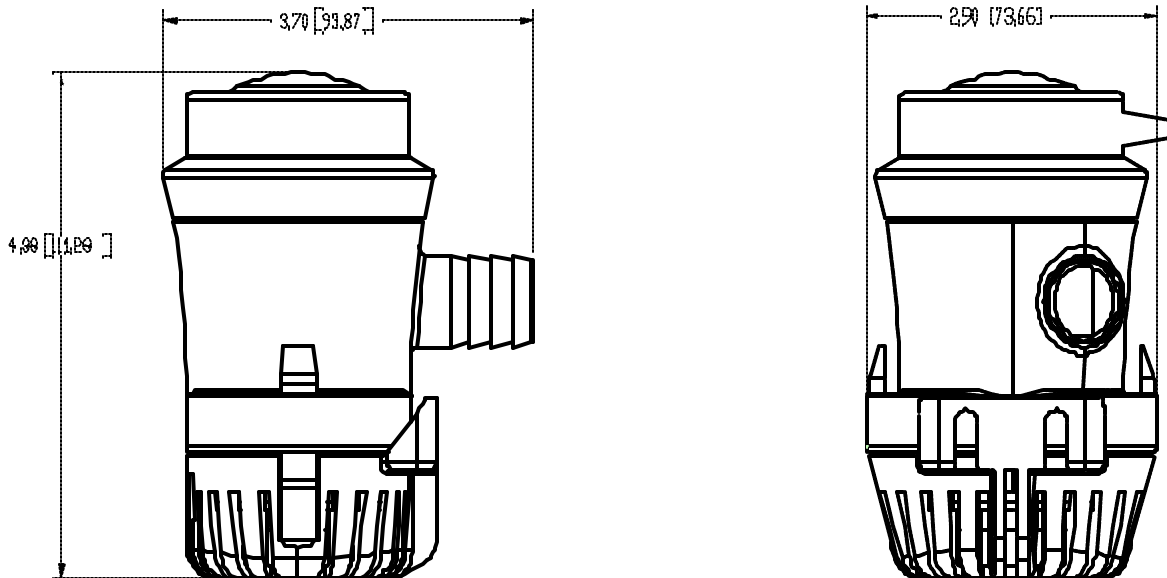

*ISO Registered Facility

SHURflo reserves the right to update specifications, prices, or make substitutions.

SHURflo *
 5900A Katella Ave.
 Cypress, Ca. 90630
 (800) 854-3218 (562) 795-5200
 FAX (562) 795-7554
 Shipping/UPS: 5900C Katella Ave.
 Cypress, Ca. 90630

SHURflo East
 52748 Park Six Court
 Elkhart, IN 46514-5427
 (800) 762-809 (574) 262-0478
 FAX (574) 264-2169
 Http://www.shurflo.com
 © 2001

SHURflo Ltd. *
 Unit 5 Sterling Park
 Gatwick Road, Crawley
 West Sussex, RH10 2QT
 United Kingdom
 +44 1293 424000
 FAX +44 1293 421880

