

MACERATOR



MARINE PRODUCT DATA SHEET

OEM: 3200-010
AFTERMARKET: 3200-011

Designed specifically for sanitation waste and fish box evacuation, SHURflo's Macerator pump features a premium impeller design with run-dry capability and includes our seamless shell e-coated motor with o-ring sealed and bells and sealed manual turn key. SHURflo's unique dual blade and housing construction ensures problem free pumping, providing superior performance in harsh marine environments.

PUMP

Type: Centrifugal Pump
Inlet Port: 1 1/2" Barb / 1 1/2 NPT
Outlet Port: 1.0" Barb
Liquid: 130 °F [54 °C] Max
Prime: 4 feet [1.21 M]
Inlet PSI: 30 PSI [2.1 Bar] Max
Run Dry: Yes - 3 Minutes

TYPICAL APPLICATIONS

24V DC Macerator Pump Designed specifically for sanitation waste and fish box evacuation. For other applications, contact SHURflo.

ELECTRICAL

Motor: 24VDC Permanent Magnet, Intermittent Duty
Protection: Thermal Overload, Automatic Restart
Leads: 14 AWG, 17 1/2" [44 cm] Pos +, 18 1/2" [47 cm] Neg -
Fuse: 15 Amp Recommended
Control: No Control

MATERIALS

Housing: Phenolic - Nylon
Impeller: Polyurethane
Hardware: Stainless Steel

APPROVALS

Ignition Protected, CE, ISO 8846

WARRANTY

1 Year Limited Warranty
See SB-1050 For Full Warranty Details

SHIPPING

Net Weight (Boxed): 6 Lb [2.7 Kg] each
Carton Weight: 36 Lb [16.3 Kg]
Pumps in Carton: 6
Carton Size: 24"L x 18"W x 6"H [61 cm x 46 cm x 15 cm]

RELATED DOCUMENTS

Catalog: MS-030-140
Installation Manual: 911-566
Maintenance: 911-566
Applications Spec Guide: MS-020-005
Warranty: SB-1050

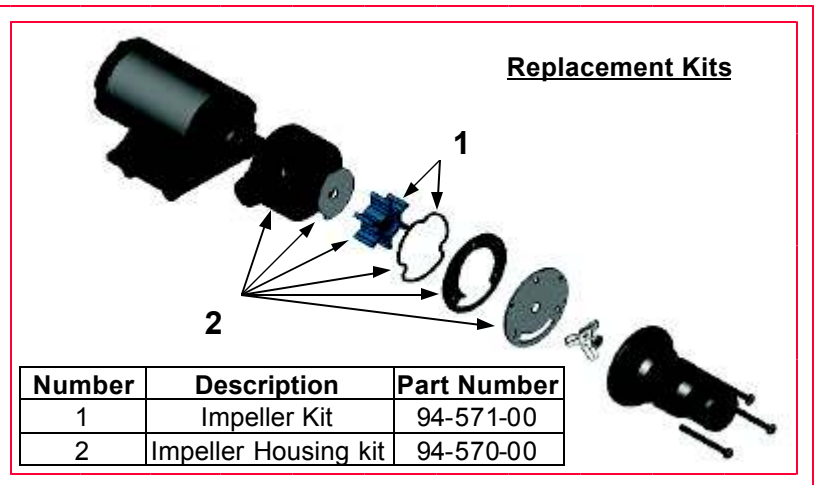

PERFORMANCE @ 24V DC

PRESSURE		FLOW		CURRENT
BAR	PSI	GPM	LPM	AMPS
0.0	0	11	41.6	5.9
0.27	4	8	30.3	7.1
0.55	8	7	26.4	7.4
0.82	12	5	18.9	8.0
1.10	18	0.0	0.0	9.1

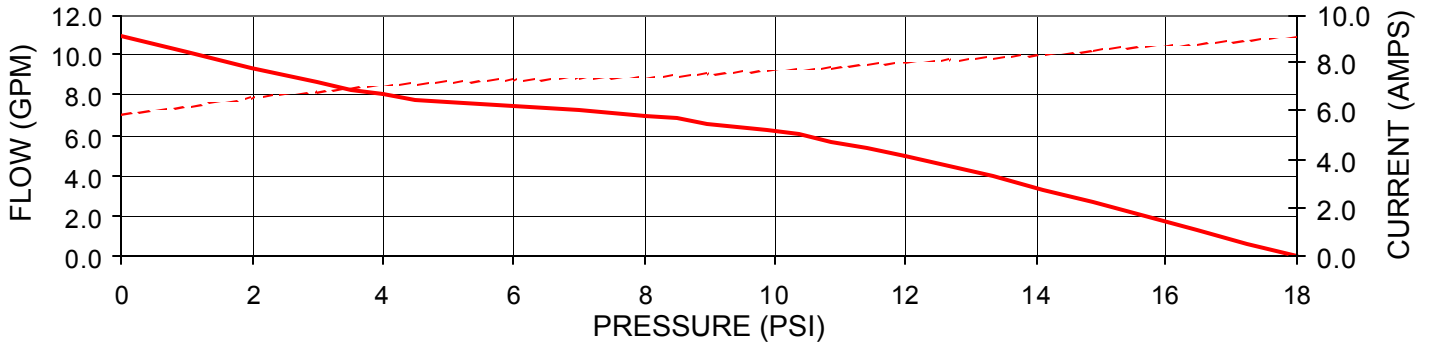

DIMENSIONS [mm]

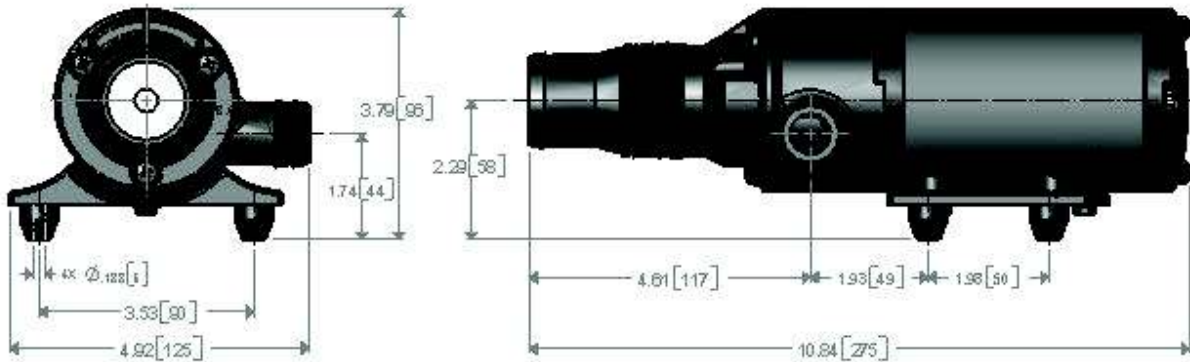

*ISO Registered Facility *SHURflo reserves the right to update specifications, prices, or make substitutions.*

SHURflo *
 5900A Katella Ave.
 Cypress, Ca. 90630
 (800) 854-3218 (562) 795-5200
 FAX (562) 795-7554
 Shipping/UPS: 5900C Katella Ave.
 Cypress, Ca. 90630

SHURflo East
 52748 Park Six Court
 Elkhart, IN 46514-5427
 (800) 762-809 (574) 262-0478
 FAX (574) 264-2169
 Http://www.shurflo.com
 © 2001

SHURflo Ltd. *
 Unit 5 Sterling Park
 Gatwick Road, Crawley
 West Sussex, RH10 2QT
 United Kingdom
 +44 1293 424000
 FAX +44 1293 421880

