

# MACERATOR



## MARINE PRODUCT DATA SHEET

**OEM: 3200-000**  
**AFTERMARKET: 3200-001**

Designed specifically for sanitation waste and fish box evacuation, SHURflo's Macerator pump features a premium impeller design with run-dry capability and includes our seamless shell e-coated motor with o-ring sealed and bells and sealed manual turn key. SHURflo's unique dual blade and housing construction ensures problem free pumping, providing superior performance in harsh marine environments.

### PUMP

Type: Centrifugal Pump  
Inlet Port: 1 1/2" Barb / 1 1/2 NPT  
Outlet Port: 1.0" Barb  
Liquid: 130 °F [54 °C] Max  
Prime: 4 feet [1.21 M]  
Inlet PSI: 30 PSI [2.1 Bar] Max  
Run Dry: Yes - 3 Minutes

### TYPICAL APPLICATIONS

12V DC Macerator Pump Designed specifically for sanitation waste and fish box evacuation. For other applications, contact SHURflo.

### ELECTRICAL

Motor: 12VDC Permanent Magnet, Intermittent Duty  
Protection: Thermal Overload, Automatic Restart  
Leads: 14 AWG, 17 1/2" [44 cm] Pos +, 18 1/2" [47 cm] Neg -  
Fuse: 25 Amp Recommended  
Control: No Control

### MATERIALS

Housing: Phenolic - Nylon  
Impeller: Polyurethane  
Hardware: Stainless Steel

### APPROVALS

Ignition Protected, CE, ISO 8846

### WARRANTY

1 Year Limited Warranty  
See SB-1050 For Full Warranty Details

### SHIPPING

Net Weight (Boxed): 6 Lb [2.7 Kg] each  
Carton Weight: 36 Lb [16.3 Kg]  
Pumps in Carton: 6  
Carton Size: 24"L x 18"W x 6"H [61 cm x 46 cm x 15 cm]

### RELATED DOCUMENTS

Catalog: MS-030-140  
Installation Manual: 911-566  
Maintenance: 911-566  
Applications Spec Guide: MS-020-005  
Warranty: SB-1050

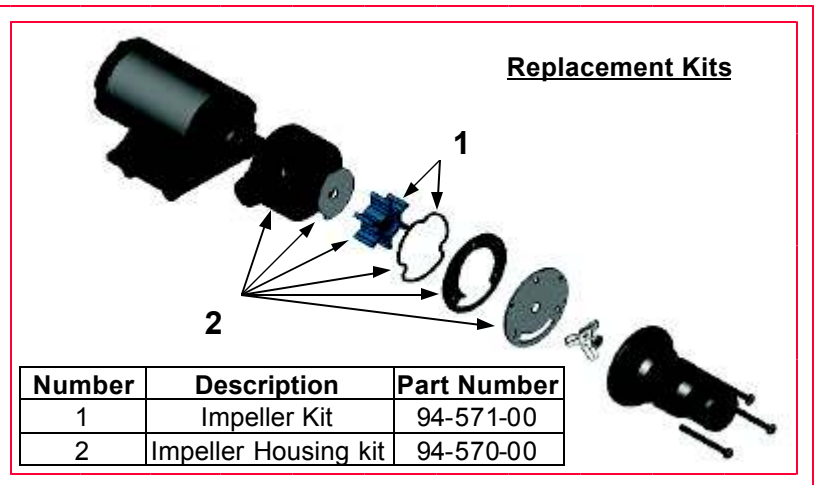

PERFORMANCE @ 12V DC

PRESSURE		FLOW		CURRENT
BAR	PSI	GPM	LPM	AMPS
0.0	0	13	49.2	13.8
0.27	4	8	30.3	14.5
0.55	8	6	22.7	16.1
0.82	12	4	15.1	16.8
1.10	16	0.0	0.0	17.0

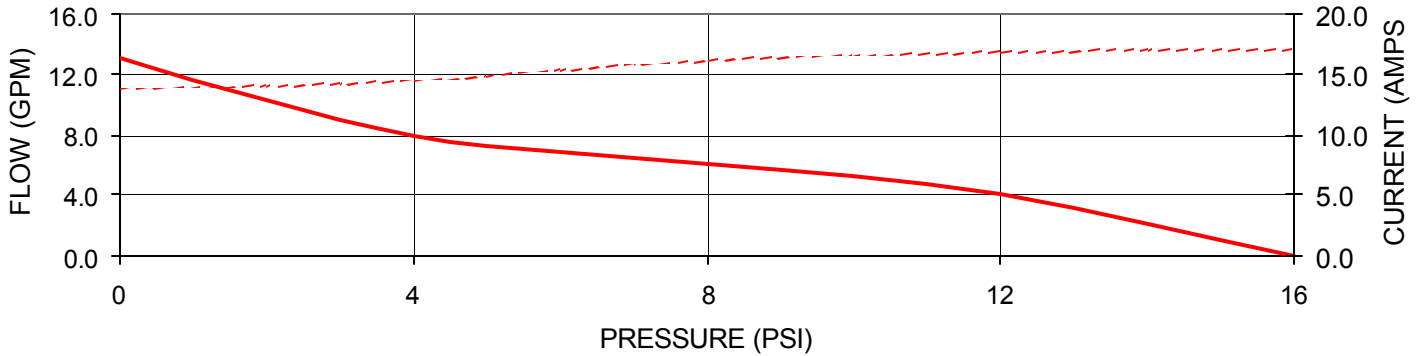

DIMENSIONS [mm]

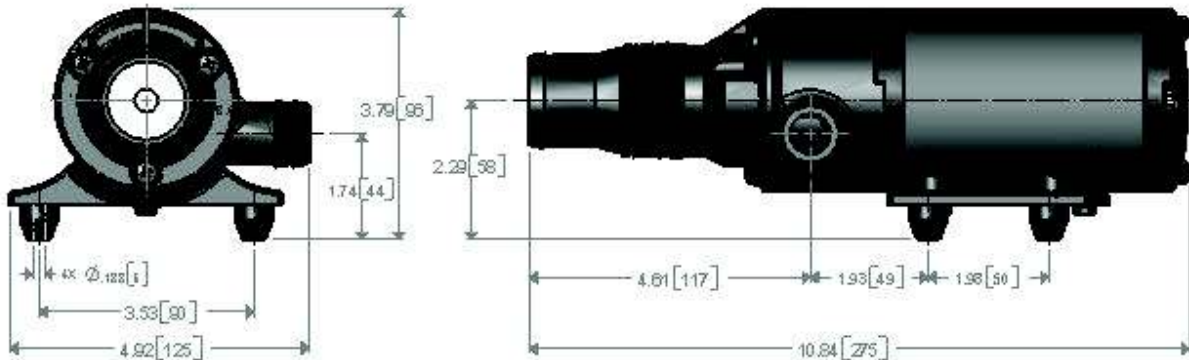

\*ISO Registered Facility SHURflo reserves the right to update specifications, prices, or make substitutions.

SHURflo \*  
 5900A Katella Ave.  
 Cypress, Ca. 90630  
 (800) 854-3218 (562) 795-5200  
 FAX (562) 795-7554  
 Shipping/UPS: 5900C Katella Ave.  
 Cypress, Ca. 90630

SHURflo East  
 52748 Park Six Court  
 Elkhart, IN 46514-5427  
 (800) 762-809 (574) 262-0478  
 FAX (574) 264-2169  
 Http://www.shurflo.com  
 © 2001

SHURflo Ltd. \*  
 Unit 5 Sterling Park  
 Gatwick Road, Crawley  
 West Sussex, RH10 2QT  
 United Kingdom  
 +44 1293 424000  
 FAX +44 1293 421880

