

MARINE PRODUCT DATA SHEET

OEM 3101-000
 AFTERMARKET N/A



Aqua Tiger

TYPICAL APPLICATIONS

General plumbing applications where a flooded inlet is provided, such as livewell filling and circulation, liquid transfer, shower pump or washdown systems 24V DC. For other applications, contact SHURflo.

PUMP

Type: Centrifugal Pump
 Ports: 3/4" NPTF
 Liquid: 130 °F [54 °C] Max
 Prime: Flooded Inlet
 Inlet PSI: 30 PSI [2.1 Bar] Max
 Run Dry: No

ELECTRICAL

Motor: 24VDC Permanent Magnet, Continuous Duty
 Protection: External Fuse
 Leads: 14 AWG, 17 1/2" [44cm] Red +, 18 1/2" [47cm] Black -
 Fuse: 7.5 Amp Recommended
 Control: No Control

MATERIALS

Housing: Stainless Steel
 Impeller: Stainless Steel
 Hardware: Stainless Steel

APPROVALS

Ignition Protected, ISO 8846

WARRANTY

1 Year Limited Warranty
 See SB-1050 For Full Warranty Details

SHIPPING

Net Weight (Boxed): 6.8 Lb [3.1 Kg] each
 Carton Weight: 6 each, 41 Lb [18.5 Kg]
 Carton Size: 24"L x 18"W x 6"H
 [61cm x 46 cm x cm]

RELATED DOCUMENTS

Catalog: MS-030-083 / 030-084
 Installation Manual: 911-548
 Maintenance: 911-548
 Applications Spec Guide: MS-020-005
 Warranty: SB-1041 / SB-1050

Parts Kits

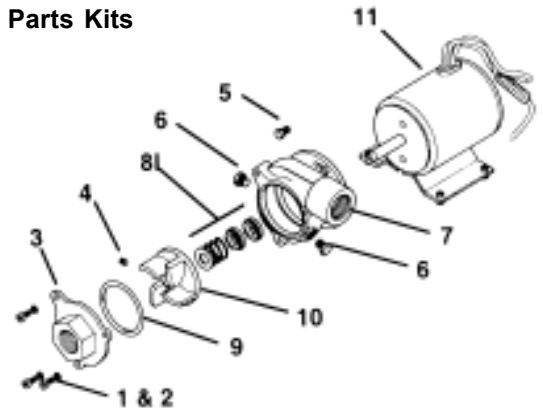

Item	Description	Qty
1	Cover Screw	3
2	Lock Washer	3
3	Cover	1
4	Set Screw (3/32")	1
5	Hex Head Screw (5/16")	2
6	Pipe Plug (7/16")	2
7	Housing	1
8	Mechanical Seal Assembly	1
9	O-ring, Viton	1



MARINE PRODUCT DATA SHEET

OEM 3101-000
 AFTERMARKET N/A



TYPICAL PERFORMANCE @ 24V DC

PRESSURE		FLOW		CURRENT
BAR	PSI	GPM	LPM	AMPS
0.00	0	20.0	75.7	5.2
0.13	2	18.0	68.1	4.8
0.27	4	14.0	52.9	4.1
0.41	6	10.0	37.8	3.8
0.68	8.6	0.0	0.0	2.8

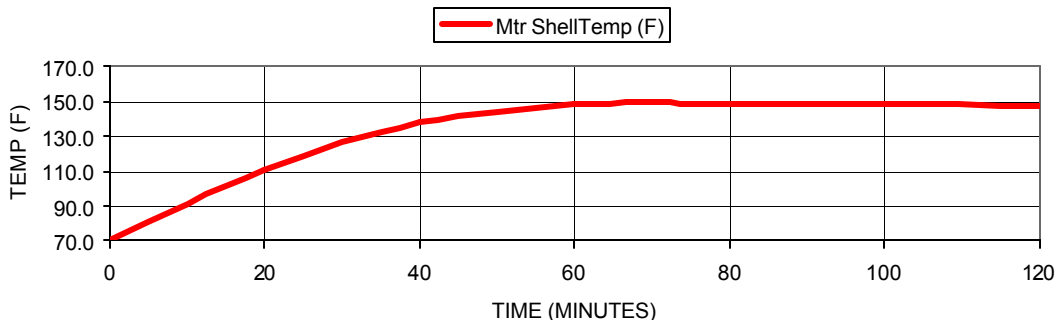

DIMENSIONS [mm]

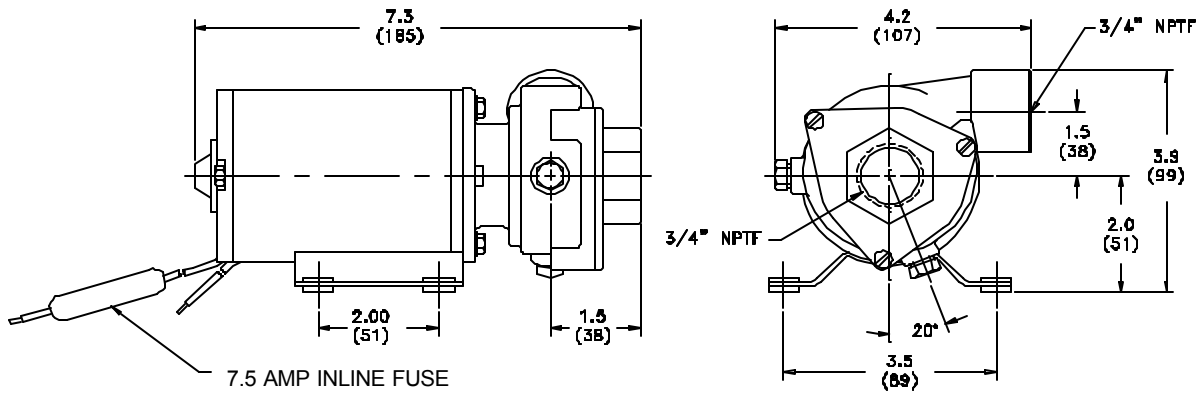

*ISO Registered Facility

SHURflo reserves the right to update specifications, prices, or make substitutions.

SHURflo *
 5900A Katella Ave.
 Cypress, Ca. 90630
 (800) 854-3218 (562) 795-5200
 FAX (562) 795-7554
 Shipping/UPS: 5900C Katella Ave.
 Cypress, Ca. 90630

SHURflo East
 52748 Park Six Court
 Elkhart, IN 46514-5427
 (800) 762-809 (574) 262-0478
 FAX (574) 264-2169
 Http://www.shurflo.com
 © 2001

SHURflo Ltd. *
 Unit 5 Sterling Park
 Gatwick Road, Crawley
 West Sussex, RH10 2QT
 United Kingdom
 +44 1293 424000
 FAX +44 1293 421880

