



MARINE PRODUCT DATA SHEET

OEM: 2901-0203
AFTERMARKET: 2901-0213

The Next Generation SHURflo pumps guarantee quiet operation and smooth performance while providing the ultimate in durability and reliability. Designed and built specially for the harsh marine environment, the Next Generation SHURflo pumps are equipped with sealed switches and seamless e-coated motors.

TYPICAL APPLICATIONS

Multi-fixture marine fresh water installation. Other uses may include 12V DC pressurized water systems in cabins. This pump may be used for general water transfer. For other applications contact SHURflo.

PUMP:

Type: 3 Chamber Diaphragm
Ports: 1/2"-14 NPSM-Male.
Liquid: 130 °F [54 °C] Max
Prime: 6 feet [1.82 M]
Inlet PSI: 30 PSI [2.1 Bar] Max
Run Dry: Yes

ELECTRICAL:

Motor: 12VDC Permanent Magnet, Intermittent Duty
Protection: Thermal Overload, Automatic Restart
Leads: 16 AWG, 16" [40 cm] Red +, 13" [33 cm] Black -
Fuse: 7 Amp Recommended
Control: Adjustable Switch. Shut-Off 30 PSI [2.0 Bar] ± 5 PSI [0.4 Bar]
Restart 15 PSI [1.0 Bar] ± 5 PSI [0.4 Bar]

MATERIALS:

Housing: Polypro
Valves: EPDM
Diaphragm: Santoprene
Hardware: Stainless Steel

APPROVALS:

Ignition Protected, CE, ISO 8846

WARRANTY:

3 Year Limited Warranty
See SB-1050 For Full Warranty Details

SHIPPING:

Net Weight (Boxed): 4.8 Lb [2.2 Kg] each
Carton Weight: 58 Lb [26.3 Kg]
Carton Size: 24"L x 18"W x 11"H
[60.9 cm x 45.7 cm x 27.9 cm]

RELATED DOCUMENTS:

Catalog: MS-030-140
Installation Manual: 911-740
Maintenance: 911-740
Applications Spec Guide: MS-020-005
Warranty: SB-1050

Replacement Kits

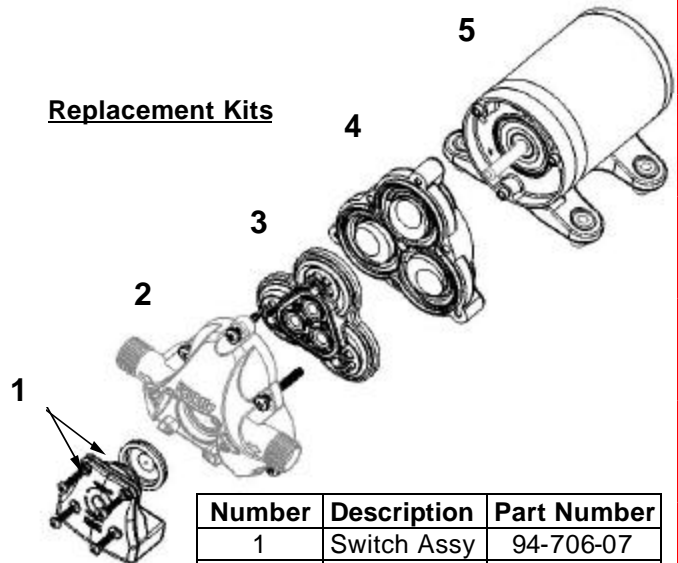

Number	Description	Part Number
1	Switch Assy	94-706-07
2	Upper Hsg	94-706-01
3	Valve Assy	94-706-02
4	Drive Assy	94-706-06
5	Motor	77-035-17



PERFORMANCE @ 12V DC

PRESSURE		FLOW		CURRENT
BAR	PSI	GPM	LPM	AMPS
0.0	0	2.20	8.32	2.30
0.7	10	1.58	5.98	2.95
1.4	20	1.00	3.78	3.41
2.1	30	0.68	2.57	3.60

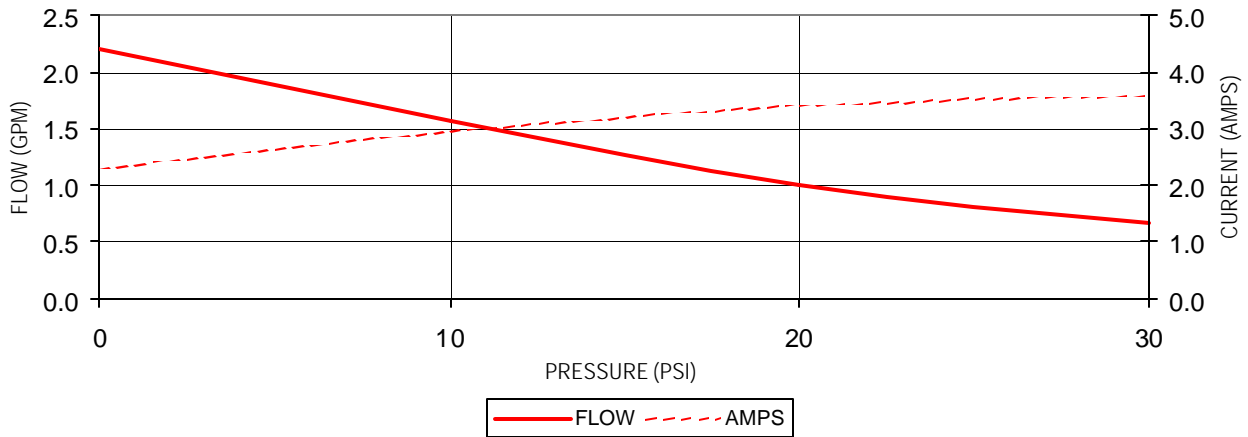

DIMENSIONS [mm]

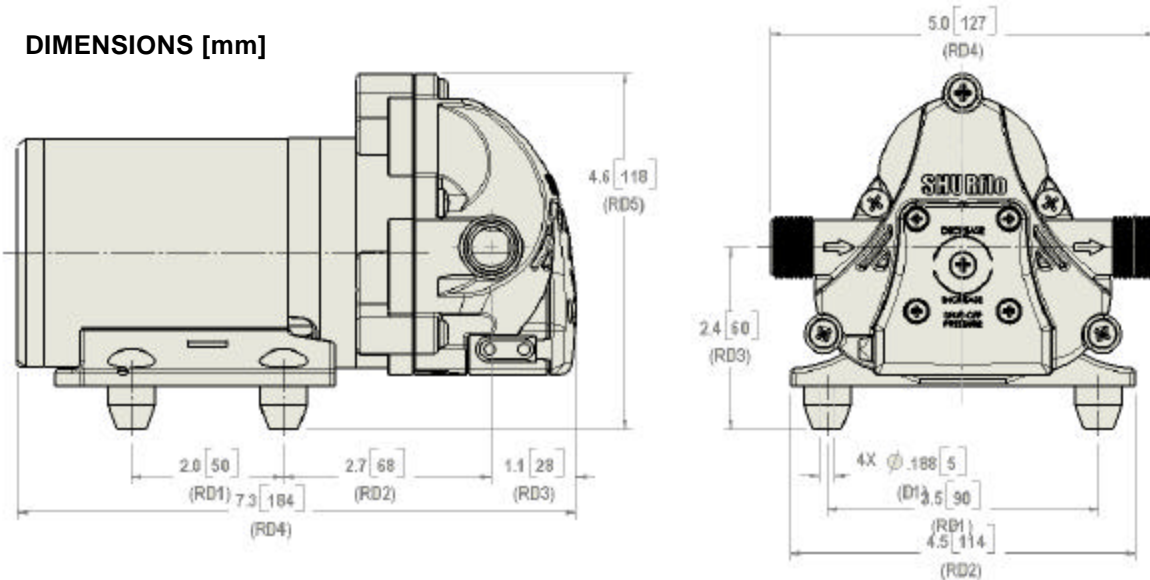

*ISO Registered Facility *SHURflo reserves the right to update specifications, prices, or make substitutions.*

SHURflo *
 5900A Katella Ave.
 Cypress, Ca. 90630
 (800) 854-3218 (562) 795-5200
 FAX (562) 795-7554
 Shipping/UPS: 5900C Katella Ave.
 Cypress, Ca. 90630

SHURflo East
 52748 Park Six Court
 Elkhart, IN 46514-5427
 (800) 762-809 (574) 262-0478
 FAX (574) 264-2169
 Http://www.shurflo.com
 ©2001

SHURflo Ltd. *
 Unit 5 Sterling Park
 Gatwick Road, Crawley
 West Sussex, RH10 2QT
 United Kingdom
 +44 1293 424000
 FAX +44 1293 421880

