

MARINE PRODUCT DATA SHEET

OEM
AFTERMARKET

2095-223-264



Aqua King Standard



TYPICAL APPLICATIONS

Multi-fixture marine potable water installations. Other uses may include 12 VDC pressurized water systems in cabins. This pump may be used for general water transfer. For other applications, contact SHURflo.

PUMP

Type: 3 Chamber Diaphragm
Ports: 1/2"-14 NPSM-Male
Liquid: 130 °F [54 °C] Max
Prime: 6 feet [1.82 M]
Inlet PSI: 30 PSI [2.1 Bar] Max
Run Dry: Yes

ELECTRICAL

Motor: 12VDC Permanent Magnet, Intermittent Duty
Protection: Thermal Overload, Automatic Restart
Leads: 16 AWG, 16" [40 cm] Red +, 38" [33 cm] Black -
Fuse: 10 Amp Recommended
Control: Adjustable Switch with Check Valve Shut-Off 45 PSI
[3.1 Bar] ± 5 PSI [0.4 Bar]
Restart 25 PSI [1.8 Bar] ± 5 PSI [0.4 Bar]

MATERIALS

Housing: Polypropylene
Valves: EPDM
Diaphragm: Santoprene
Hardware: Stainless Steel

APPROVALS

UL Marine, Ignition Protected, ISO 8846, c-UL

WARRANTY

1 Year Limited Warranty
See SB-1050 For Full Warranty Details

SHIPPING

Net Weight (Boxed): 5 Lb [2.3Kg] each
Carton Weight: 12 each, 52 Lb [24 Kg]
Carton Size: 24"L x 18"W x 11"H
[61cm x 46cm x 28cm]

RELATED DOCUMENTS

Catalog: MS-030-084
Installation Manual: 911-448
Maintenance: 911-448
Applications Spec Guide: MS-020-005
Warranty: SB-1050

Parts Kits

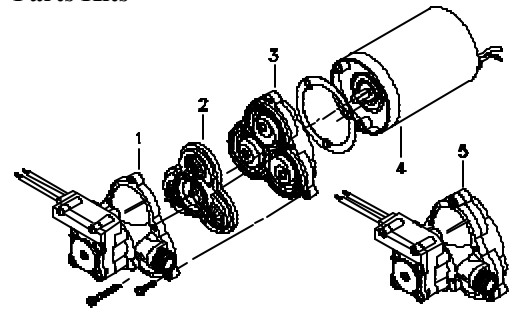

Number	Component	Parts Kit
1	Housing/Switch	94-231-10
2	Valve Assembly	94-232-06
3	Drive Assembly	94-238-04
4	Motor	11-148-06
5	Pump Head	94-236-03
Not Shown	Check Valve	94-237-00



MARINE PRODUCT DATA SHEET

OEM
AFTERMARKET

2095-223-264



TYPICAL PERFORMANCE @ 12V DC

PRESSURE		FLOW		CURRENT
BAR	PSI	GPM	LPM	AMPS
0.0	0	2.8	10.2	3.1
0.7	10	2.2	8.3	4.0
1.4	20	1.8	6.9	4.5
2.1	30	1.3	4.9	4.8
2.8	40	0.9	3.4	4.6

— FLOW - - - AMPS

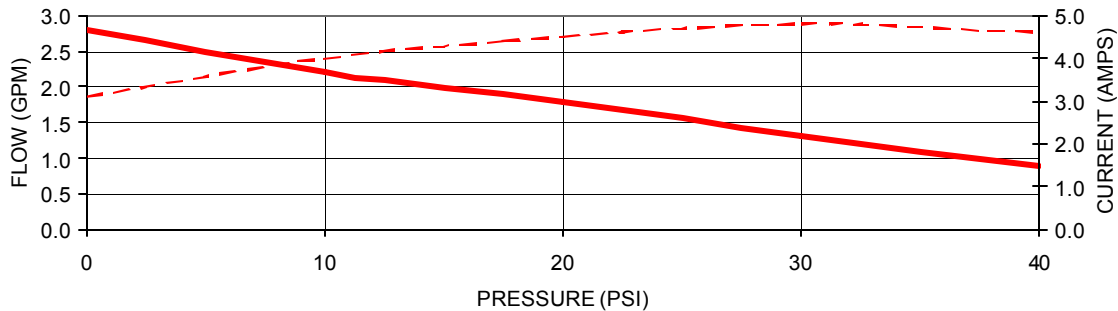

DIMENSIONS [mm]

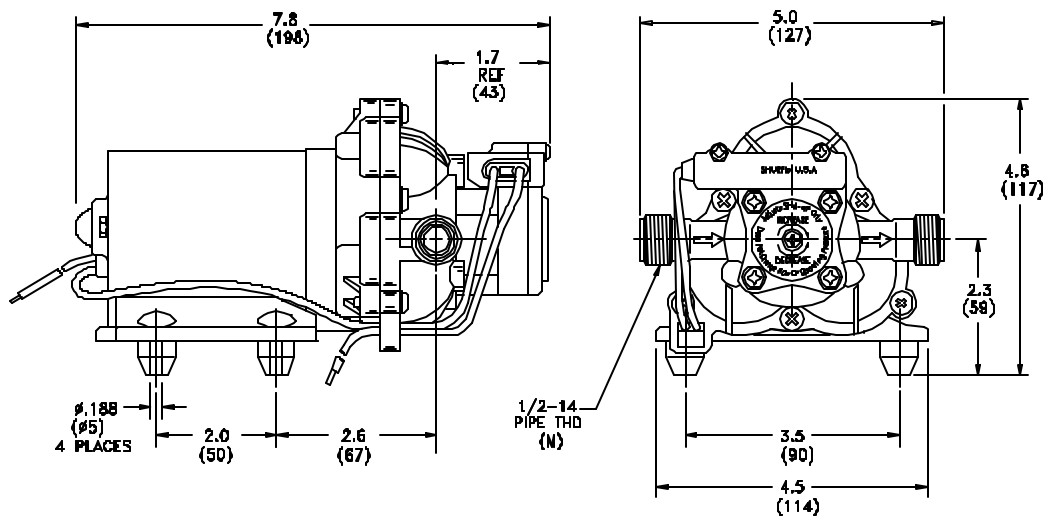

*ISO Registered Facility

SHURflo reserves the right to update specifications, prices, or make substitutions.

SHURflo *
5900A Katella Ave.
Cypress, Ca. 90630
(800) 854-3218 (562) 795-5200
FAX (562) 795-7554
Shipping/UPS: 5900C Katella Ave.
Cypress, Ca. 90630

SHURflo East
52748 Park Six Court
Elkhart, IN 46514-5427
(800) 762-809 (574) 262-0478
FAX (574) 264-2169
Http://www.shurflo.com
© 2001

SHURflo Ltd. *
Unit 5 Sterling Park
Gatwick Road, Crawley
West Sussex, RH10 2QT
United Kingdom
+44 1293 424000
FAX +44 1293 421880

