

# MARINE PRODUCT DATA SHEET

OEM 2088-723-244  
 AFTERMARKET 2088-423-344



## Aqua King Standard



### TYPICAL APPLICATIONS

Multi-fixture marine potable water installations. Other uses may include 12 VDC pressurized water systems in cabins. This pump may be used for general water transfer. For other applications, contact SHURflo.

### PUMP

Type: 3 Chamber Diaphragm  
 Ports: 1/2"-14 NPSM-Male  
 Liquid: 130 °F [54 °C] Max  
 Prime: 6 feet [1.82 M]  
 Inlet PSI: 30 PSI [2.1 Bar] Max  
 Run Dry: Yes

### ELECTRICAL

Motor: 12VDC Permanent Magnet, Intermittent Duty  
 Protection: Thermal Overload, Automatic Restart  
 Leads: 16 AWG, 16" [40 cm] Red +, 38" [33 cm] Black -  
 Fuse: 10 Amp Recommended  
 Control: Adjustable Switch with Check Valve Shut-Off 45 PSI  
 [3.1 Bar] ± 5 PSI [0.4 Bar]  
 Restart 25 PSI [1.8 Bar] ± 5 PSI [0.4 Bar]

### MATERIALS

Housing: Polypropylene  
 Valves: EPDM  
 Diaphragm: Santoprene  
 Hardware: Stainless Steel

### APPROVALS

UL Marine, Ignition Protected, ISO 8846, c-UL

### WARRANTY

1 Year Limited Warranty  
 See SB-1050 For Full Warranty Details

### SHIPPING

Net Weight (Boxed): 5 Lb [2.3Kg] each  
 Carton Weight: 12 each, 52 Lb [24 Kg]  
 Carton Size: 24"L x 18"W x 11"H  
 [61cm x 46cm x 28cm]

### RELATED DOCUMENTS

Catalog: MS-030-084  
 Installation Manual: 911-448  
 Maintenance: 911-448  
 Applications Spec Guide: MS-020-005  
 Warranty: SB-1050

### Parts Kits

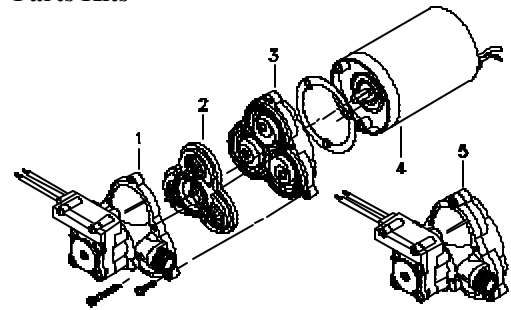

Number	Component	Parts Kit
1	Housing/Switch	94-231-10
2	Valve Assembly	94-232-06
3	Drive Assembly	94-238-04
4	Motor	11-148-06
5	Pump Head	94-236-03
Not Shown	Check Valve	94-237-00



# MARINE PRODUCT DATA SHEET

OEM 2088-723-244  
 AFTERMARKET 2088-423-244



## TYPICAL PERFORMANCE @ 12V DC

PRESSURE		FLOW		CURRENT
BAR	PSI	GPM	LPM	AMPS
0.0	0	2.8	10.2	3.1
0.7	10	2.2	8.3	4.0
1.4	20	1.8	6.9	4.5
2.1	30	1.3	4.9	4.8
2.8	40	0.9	3.4	4.6

— FLOW - - - AMPS

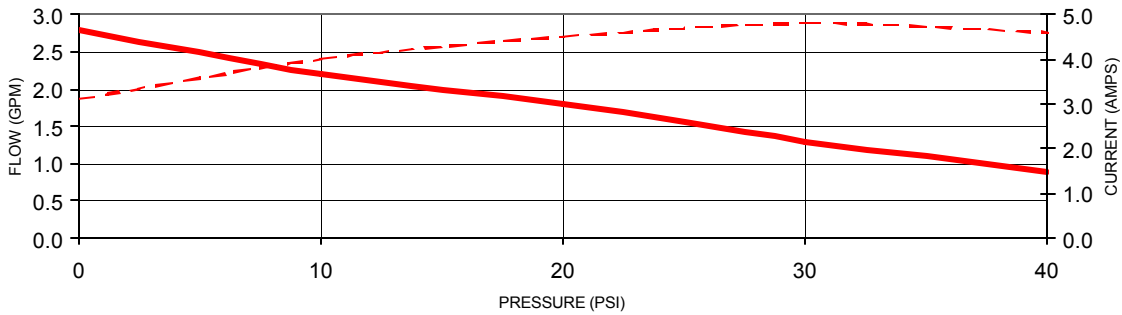

### DIMENSIONS [mm]

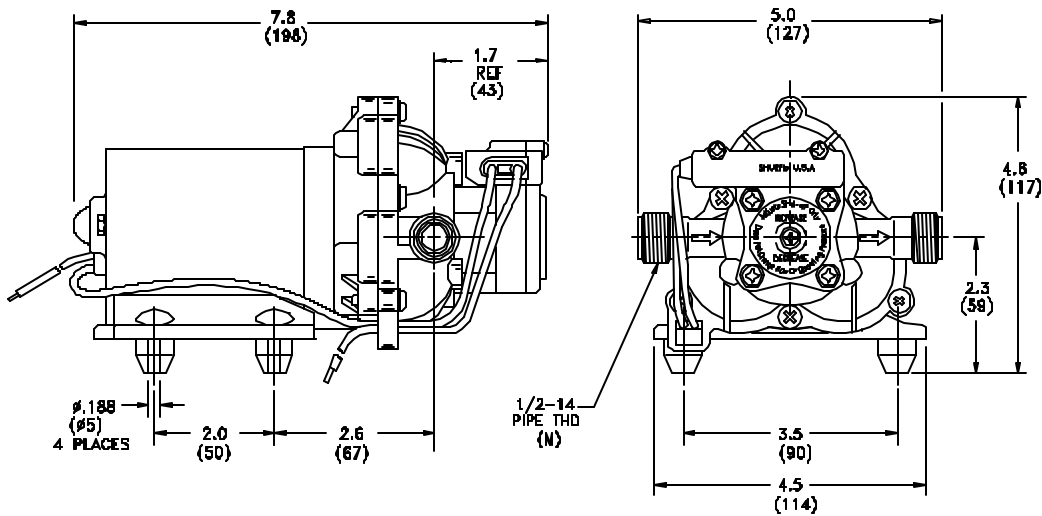

\*ISO Registered Facility

SHURflo reserves the right to update specifications, prices, or make substitutions.

SHURflo \*  
 5900A Katella Ave.  
 Cypress, Ca. 90630  
 (800) 854-3218 (562) 795-5200  
 FAX (562) 795-7554  
 Shipping/UPS: 5900C Katella Ave.  
 Cypress, Ca. 90630

SHURflo East  
 52748 Park Six Court  
 Elkhart, IN 46514-5427  
 (800) 762-809 (574) 262-0478  
 FAX (574) 264-2169  
 Http://www.shurflo.com  
 © 2001

SHURflo Ltd. \*  
 Unit 5 Sterling Park  
 Gatwick Road, Crawley  
 West Sussex, RH10 2QT  
 United Kingdom  
 +44 1293 424000  
 FAX +44 1293 421880

