

# MARINE PRODUCT DATA SHEET

OEM 2088-732-244  
 AFTERMARKET 2088-534-344



## The Blaster



### TYPICAL APPLICATIONS

Marine fresh or saltwater wash down installations. Other uses may include 12 VDC pressurized water systems. This pump may be used for general water transfer. For other applications, contact SHURflo.

### PUMP

Type: 3 Chamber Diaphragm  
 Ports: 1/2"-14 NPSM-Male  
 Liquid: 130 °F [54 °C] Max  
 Prime: 6 feet [1.82 M]  
 Inlet PSI: 30 PSI [2.1 Bar] Max  
 Run Dry: Yes

### ELECTRICAL

Motor: 12VDC Permanent Magnet, Intermittent Duty  
 Protection: Thermal Overload, Automatic Restart  
 Leads: 16 AWG, 16" [40 cm] Red +, 13" [33 cm] Black -  
 Fuse: 15 Amp Recommended  
 Control: Adjustable Switch with Check Valve  
           Shut-Off 45 PSI [3.1 Bar] ± 5 PSI [0.4 Bar]  
           Restart 25 PSI [1.8 Bar] ± 5 PSI [0.4 Bar]

### MATERIALS

Housing: Polypropylene  
 Valves: EDPM  
 Diaphragm: Santoprene  
 Hardware: Stainless Steel

### APPROVALS

UL Marine 1113, Ignition Protected, ISO 8846,  
 c-UL Meets or exceeds UL 1500 Ignition Protection.

### WARRANTY

1 Year Limited Warranty  
 See SB-1050 For Full Warranty Details

### SHIPPING

Net Weight (Boxed): 5.3 Lb [2.4Kg] each  
 Carton Weight: 12 each, 64 Lb [29 Kg]  
 Carton Size: 24"L x 18"W x 11"H  
                   [61cm x 46cm x 28cm]

### RELATED DOCUMENTS

Catalog: MS-030-084  
 Installation Manual: 911-444  
 Maintenance: 911-444  
 Applications Spec Guide: MS-020-005  
 Warranty: SB-1050

### Parts Kits

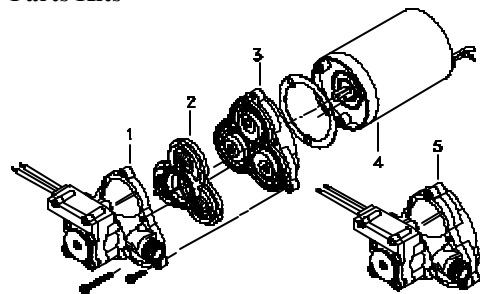

Number	Component	Parts Kit
1	Housing/Switch	94-231-10
2	Valve Assembly	94-232-06
3	Drive Assembly	94-238-03
4	Motor	11-173-06
5	Pump Head	94-236-14
Not Shown	Check Valve	94-237-00



# MARINE PRODUCT DATA SHEET

OEM 2088-732-244  
 AFTERMARKET 2088-534-344



## TYPICAL PERFORMANCE @ 12V DC

PRESSURE		FLOW		CURRENT
BAR	PSI	GPM	LPM	AMPS
0.0	0	3.5	13.2	3.7
0.7	10	2.7	10.2	4.8
1.4	20	2.4	9.0	5.8
2.1	30	2.1	7.9	6.4
2.8	40	1.8	6.8	6.7

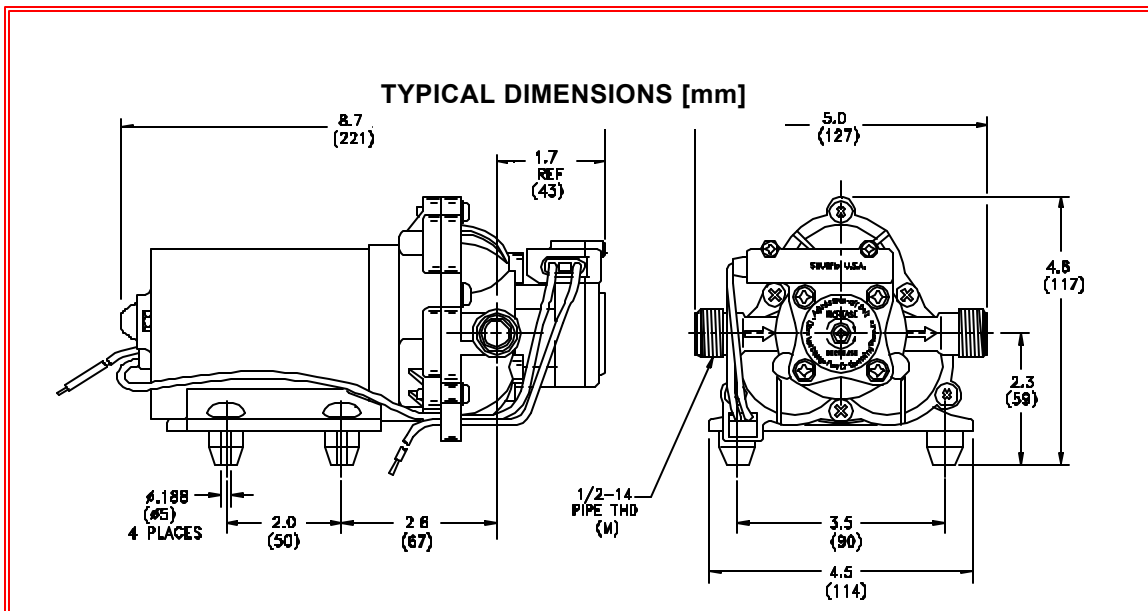
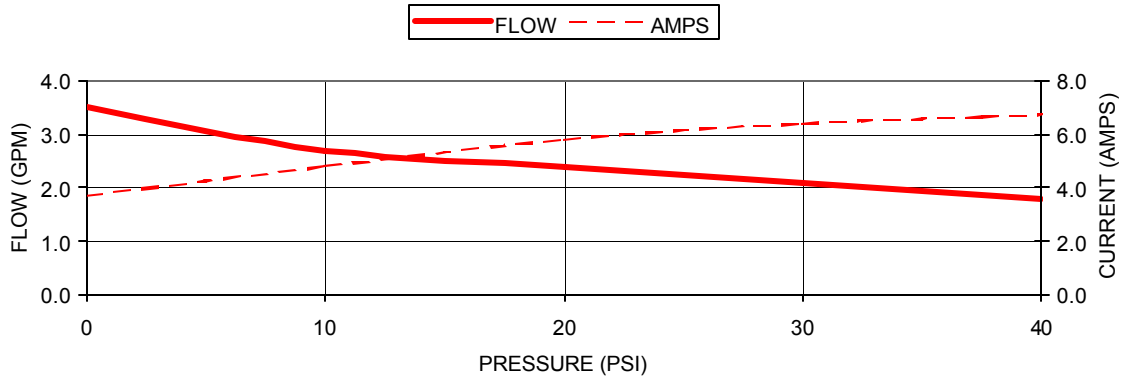

\*ISO Registered Facility

SHURflo reserves the right to update specifications, prices, or make substitutions.

SHURflo \*  
 5900A Katella Ave.  
 Cypress, Ca. 90630  
 (800) 854-3218 (562) 795-5200  
 FAX (562) 795-7554  
 Shipping/UPS: 5900C Katella Ave.  
 Cypress, Ca. 90630

SHURflo East  
 52748 Park Six Court  
 Elkhart, IN 46514-5427  
 (800) 762-809 (574) 262-0478  
 FAX (574) 264-2169  
 Http://www.shurflo.com  
 © 2001

SHURflo Ltd. \*  
 Unit 5 Sterling Park  
 Gatwick Road, Crawley  
 West Sussex, RH10 2QT  
 United Kingdom  
 +44 1293 424000  
 FAX +44 1293 421880

