

### SPECIFICATIONS:

**MODEL NUMBER:** 2088-403-144

**PUMP DESIGN:** Positive Displacement 3 Chamber Diaphragm Pump

**CHECK VALVE:** (1-Way Operation) Prevents Reverse Flow

**CAM:** 3.5 Degree

**MOTOR:** Permanent Magnet, P/N 11-148-04, Thermally Protected

**VOLTAGE:** 12 VDC Nominal

**PRESSURE SWITCH:** Adjustable from 30-50 PSI. Factory Set @ 45 PSI Shut-Off,  
Turn On  $25 \pm 5$  PSI

**LIQUID TEMPERATURE:** 130 Degrees Fahrenheit (54 Degrees Centigrade) Max.

**PRIME:** Self-Priming Up To 7.0 Ft. Vertical,  
Max. Inlet Pressure 30 PSI (2.1 Bar)

**PORTS:** 1/2" - 14 Male Parallel Thread

**MATERIAL OF CONSTRUCTION:**

**PLASTICS-** Polypropylene

**VALVES-** EPDM

**DIAPHRAGM-** Santoprene

**FASTENERS-** Zinc Plated Steel

**NET WEIGHT:** 3.7 Lbs (1.68 Kg)

**DUTY CYCLE:** Intermittent (See Temp. Rise Chart)

**TYPICAL APPLICATIONS:** RV Potable Water

**APPROVALS:** C.S.A. & I.A.P.M.O. Listed

### DIMENSIONS:

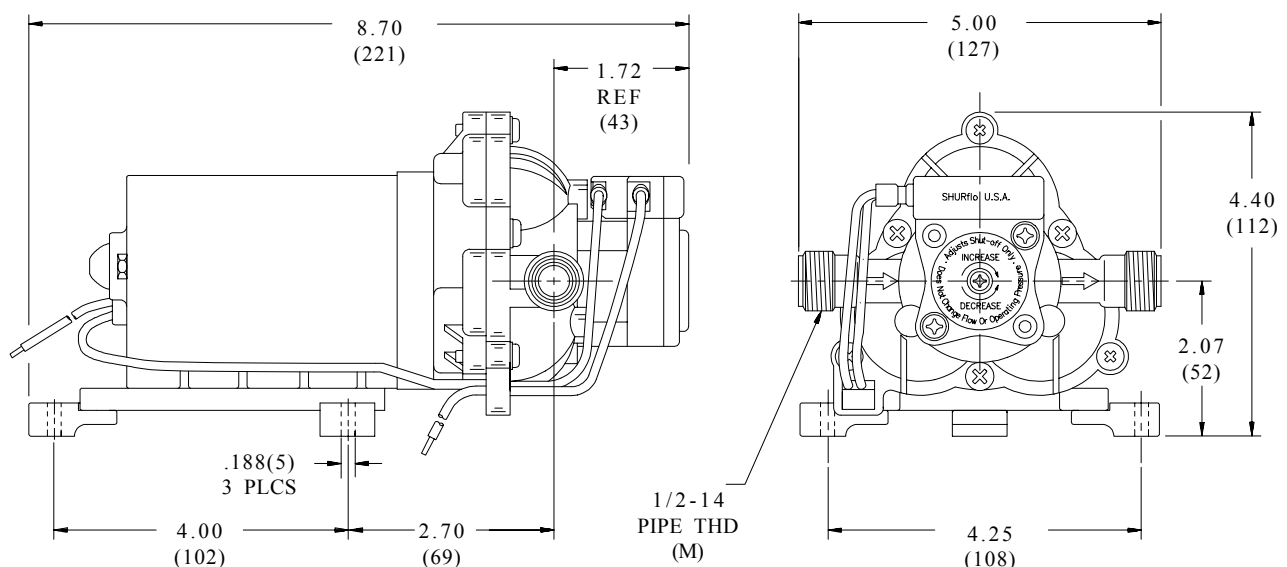

**TEMPERATURE RISE**

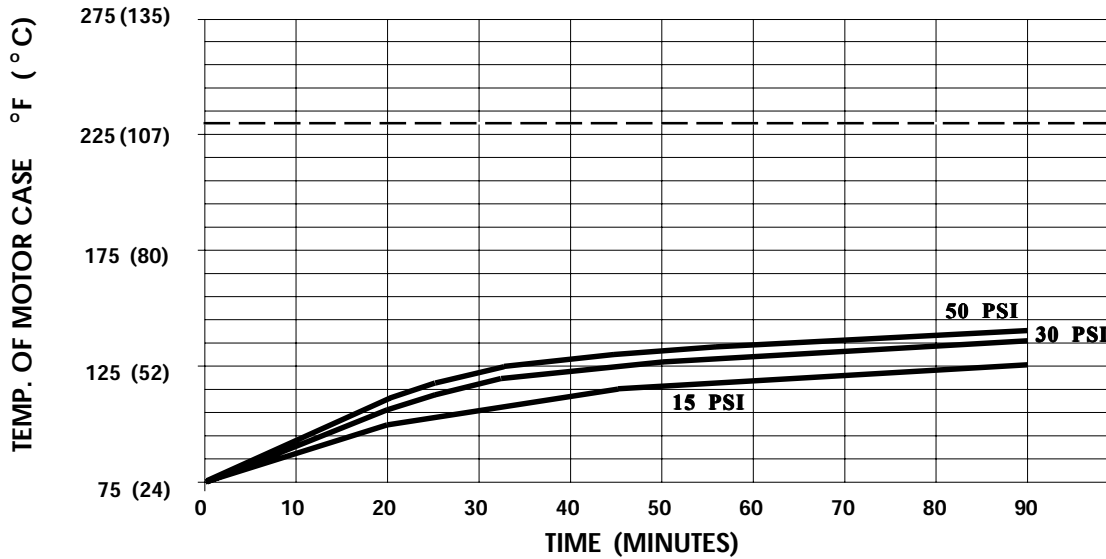

THIS GRAPH IS FOR USE AS A DESIGN GUIDE. IT IS BASED ON RUNNING CONTINUOUSLY WITH AN AMBIENT TEMPERATURE OF 70°F IN STILL AIR. THE THERMAL BREAKER WILL OPEN WHEN THE CASE TEMPERATURE REACHES 230°F.

[---- TRIP POINT OF THERMAL PROTECTOR]

**TYPICAL PERFORMANCE**

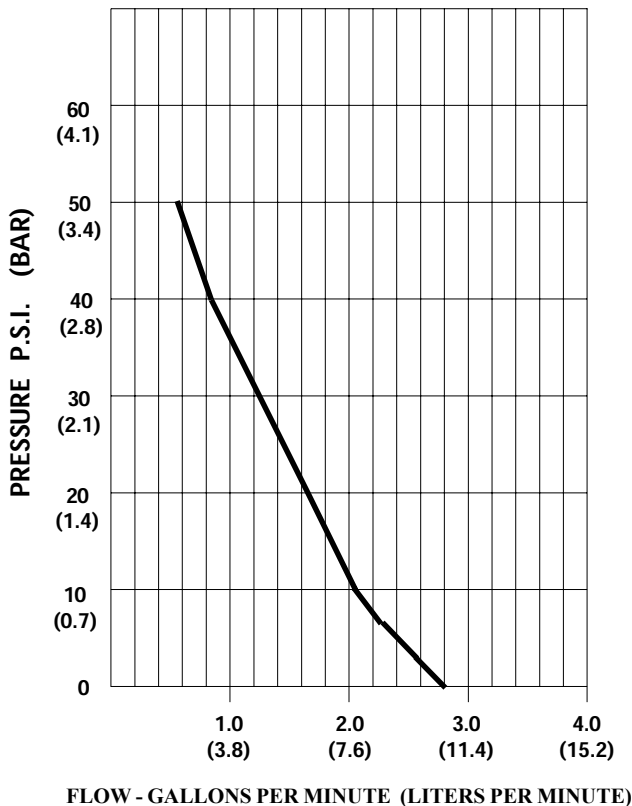

PRESSURE (PSI)	FLOW (GPM/LIT)	RPM MIN/MAX	CURRENT (AMPS)	VOLTAGE (VOLTS)
OPEN	2.80/10.6	1780/1855	3.1	12 VDC
10	2.05/7.8	1730/1800	3.7	"
20	1.65/6.2	1670/1765	4.2	"
30	1.24/4.7	1635/1755	4.5	"
40	0.86/3.2	1620/1765	4.6	"
50	0.58/2.2	1630/1795	4.5	"

*-SPECIFICATIONS SUBJECT TO CHANGE WITHOUT NOTICE.  
-ALL DATA BASED ON TESTING WITH WATER.*