

**SPECIFICATIONS:**

MODEL NUMBER: 2088-373-500

PUMP DESIGN: Positive Displacement 3 Chamber Diaphragm Pump

CAM: 3.0 Degree

MOTOR: Permanent Magnet, P/N 11-127-11

VOLTAGE: 24 VDC Nominal

PRESSURE SWITCH: None

LIQUID TEMPERATURE: 130 Degrees Fahrenheit (54 Degrees Centigrade) Max.

PRIME: Self-Priming Up To 8.0 Feet (2.4 Meters) Vertical,  
Max. Inlet Pressure 30 PSI (2.1 Bar)

PORTS: 1/2" - 14 Male Parallel Thread

MATERIAL OF CONSTRUCTION:

PLASTICS- Polypropylene

VALVES- Viton

DIAPHRAGM- Santoprene

FASTENERS- Zinc Plated Steel

NET WEIGHT: 5.0 Lbs (2.27 Kg)

DUTY CYCLE: Continuous (See Temp. Rise Chart)

TYPICAL APPLICATIONS: Endoscopy Support Equipment Washing

**DIMENSIONS:**

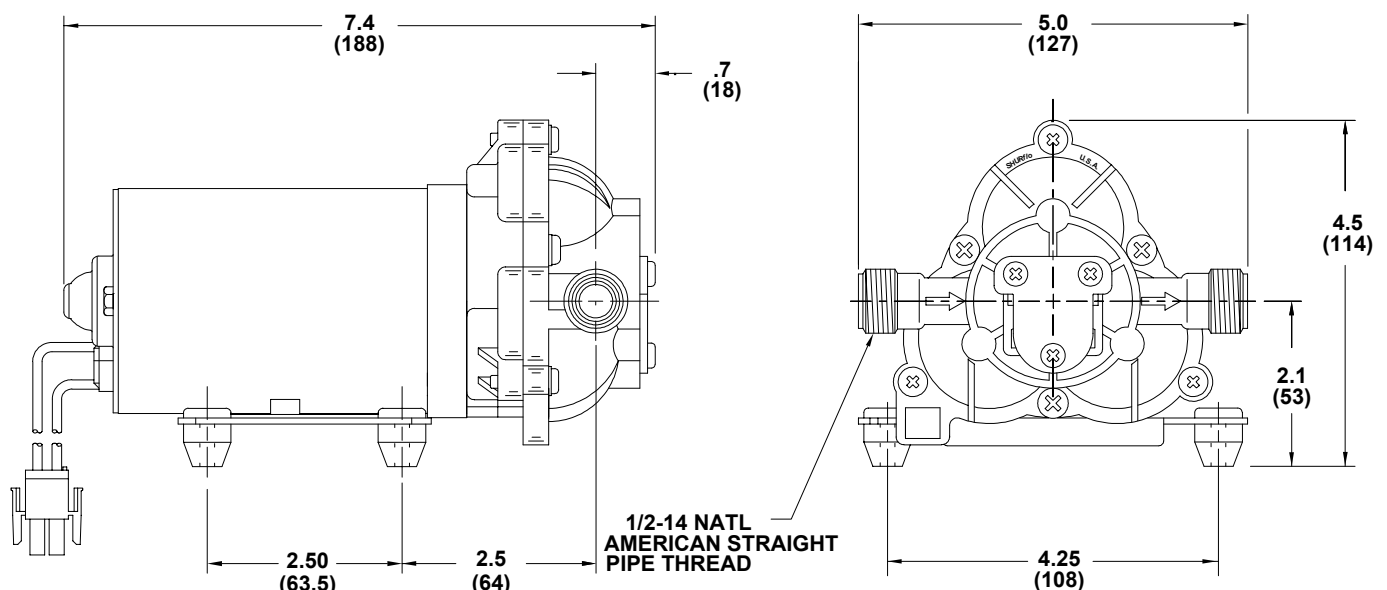

### TEMPERATURE RISE

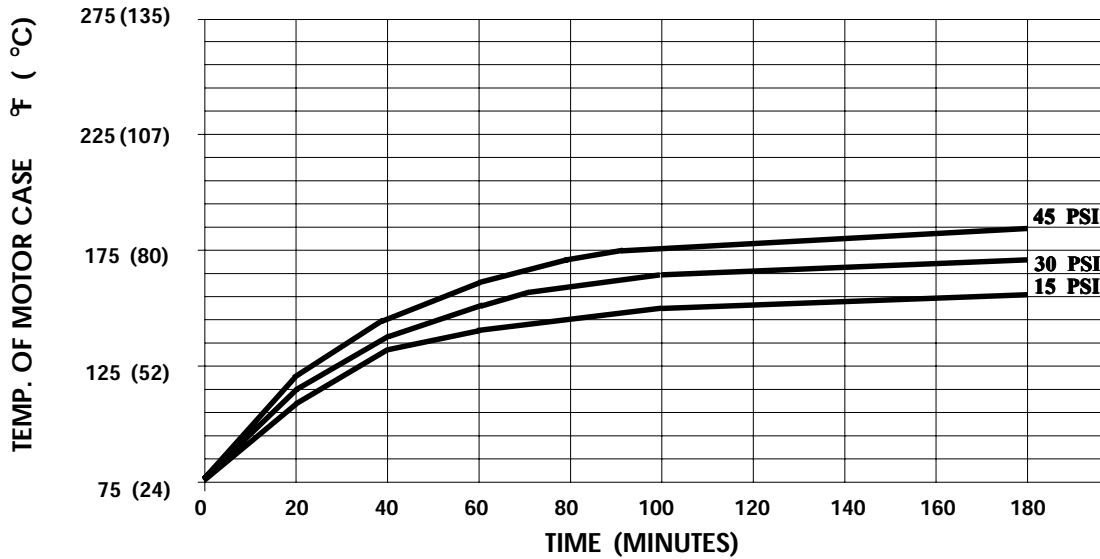

THIS GRAPH IS FOR USE AS A DESIGN GUIDE. IT IS BASED ON RUNNING CONTINUOUSLY WITH AN AMBIENT TEMPERATURE OF 75° F IN STILL AIR.

### TYPICAL PERFORMANCE

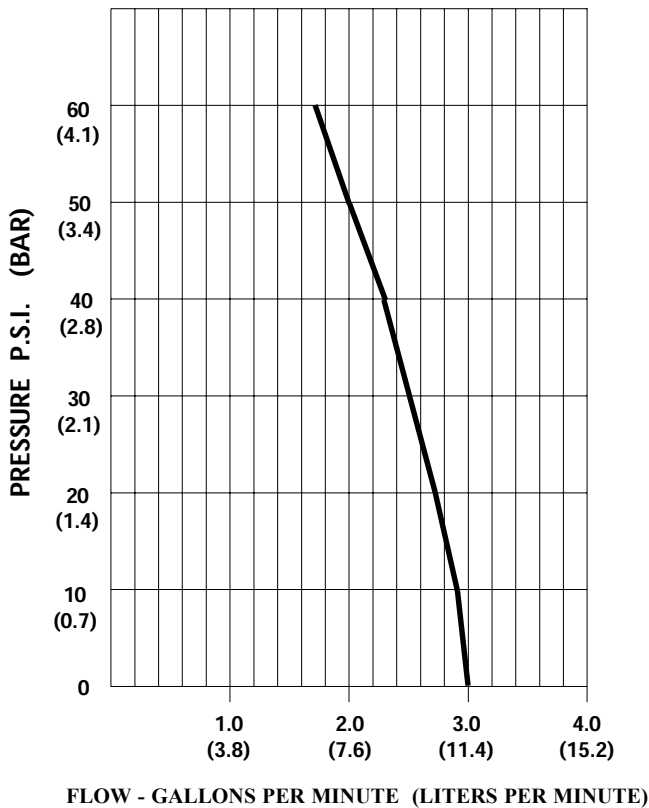

PRESSURE (PSI)	FLOW (GPM/LIT)	RPM MIN/MAX	CURRENT (AMPS)	VOLTAGE (VOLTS)
OPEN	3.0/11.4	2195/2220	2.4	24 VDC
10	2.9/11.0	2170/2200	2.5	"
20	2.7/10.2	2120/2150	3.4	"
30	2.5/9.5	2075/2100	4.0	"
40	2.3/8.7	2040/2095	4.6	"
50	2.0/7.6	2010/2015	5.1	"
60	1.7/6.4	1795/1870	5.5	"

-SPECIFICATIONS SUBJECT TO CHANGE WITHOUT NOTICE.  
 -ALL DATA BASED ON TESTING WITH WATER.