

MARINE PRODUCT DATA SHEET

OEM 1700-100-010 (500 GPH)
AFTERMARKET 1700-101-010 (500 GPH)



Magnetic Drive Bilge Pump



TYPICAL APPLICATIONS

12V Marine Bilge. For other applications, contact SHURflo.

PUMP

Type: Centrifugal Pump
Port (Output): 3/4" Barb
Liquid: 130 °F [54 °C] Max
Prime: Flooded Inlet
Inlet PSI: N/A
Run Dry: Yes

ELECTRICAL

Motor: 12VDC Permanent Magnet, Continuous Duty
Protection: External Fuse
Leads: 6 ft (1.8M) Tinned Wires, Twisted Jacketed Cable
Fuse: 2 Amp Recommended
Control: Solid State Control with Magnetic Reed Float Switch. Activation and Timed Shut-Off. After Switch Opening.

MATERIALS

Housing: High Strength Nylon
Impeller: Acetal
Hardware: Stainless Steel

APPROVALS

Ignition Protected, ISO 8846

WARRANTY

3 Year Limited Warranty
See SB-1050 For Full Warranty Details

SHIPPING

Net Weight (Boxed): 2.5 Lb [1.1 Kg] each
Carton Weight: 27 Lb [12.2 Kg]
Pumps in carton: 10
Carton Size: 24"L x 18"W x 11"H [60 cm x 45 cm x 28 cm]

RELATED DOCUMENTS

Catalog: MS-030-083 / 030-084
Installation Manual: 911-467
Maintenance: 911-467
Applications Spec Guide: MS-020-005
Warranty: SB-1041 / SB-1050

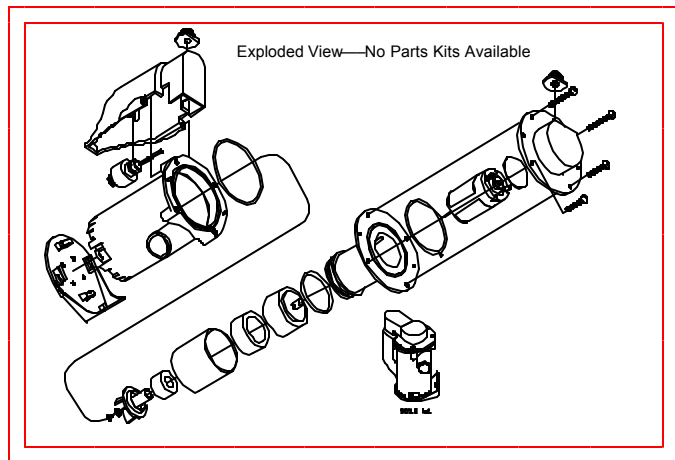

MARINE PRODUCT DATA SHEET

OEM 1700-100-010 (500 GPH)
 AFTERMARKET 1700-101-010 (500 GPH)



TYPICAL PERFORMANCE @ 12V DC

PRESSURE		FLOW		CURRENT
METERS	FT OF HEAD	GPH	LPH	AMPS
0.0	0	500	1892	1.4
0.9	3	289	1093	1.3
1.5	5	0	0	1.1

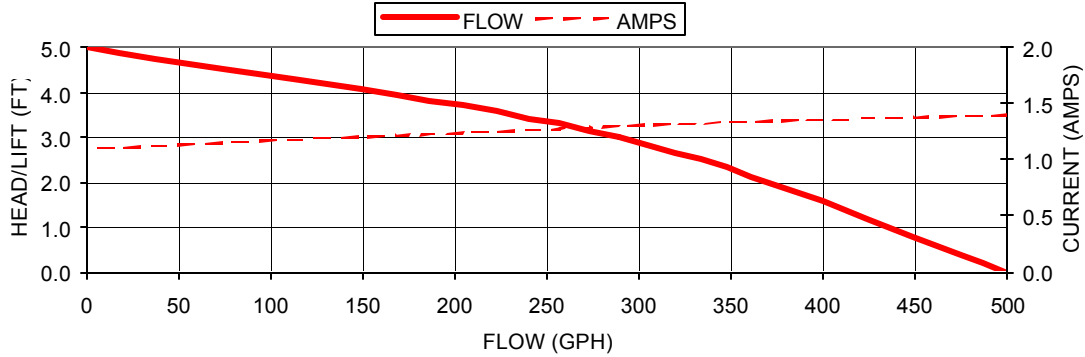

DIMENSIONS [mm]

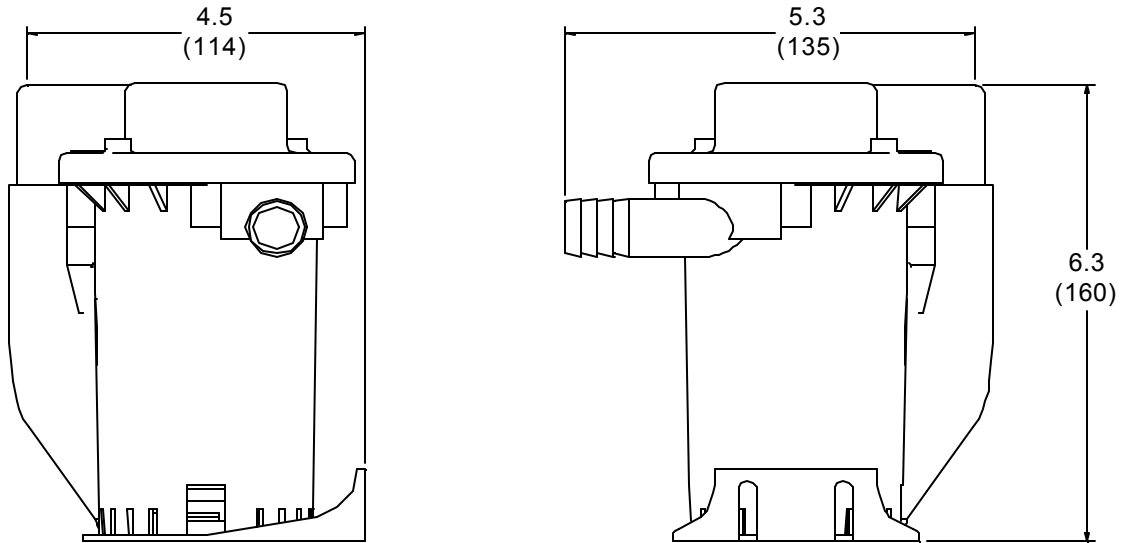

*ISO Registered Facility

SHURflo reserves the right to update specifications, prices, or make substitutions.

SHURflo *
 5900A Katella Ave.
 Cypress, Ca. 90630
 (800) 854-3218 (562) 795-5200
 FAX (562) 795-7554
 Shipping/UPS: 5900C Katella Ave.
 Cypress, Ca. 90630

SHURflo East
 52748 Park Six Court
 Elkhart, IN 46514-5427
 (800) 762-809 (574) 262-0478
 FAX (574) 264-2169
 Http://www.shurflo.com
 © 2001

SHURflo Ltd. *
 Unit 5 Sterling Park
 Gatwick Road, Crawley
 West Sussex, RH10 2QT
 United Kingdom
 +44 1293 424000
 FAX +44 1293 421880

