

# MARINE PRODUCT DATA SHEET

OEM 1700-100-010 (500 GPH)  
AFTERMARKET 1700-101-010 (500 GPH)



## Magnetic Drive Bilge Pump



### TYPICAL APPLICATIONS

12V Marine Bilge. For other applications, contact SHURflo.

### PUMP

Type: Centrifugal Pump  
Port (Output): 3/4" Barb  
Liquid: 130 °F [54 °C] Max  
Prime: Flooded Inlet  
Inlet PSI: N/A  
Run Dry: Yes

### ELECTRICAL

Motor: 12VDC Permanent Magnet, Continuous Duty  
Protection: External Fuse  
Leads: 6 ft (1.8M) Tinned Wires, Twisted Jacketed Cable  
Fuse: 2 Amp Recommended  
Control: Solid State Control with Magnetic Reed Float Switch. Activation and Timed Shut-Off. After Switch Opening.

### MATERIALS

Housing: High Strength Nylon  
Impeller: Acetal  
Hardware: Stainless Steel

### APPROVALS

Ignition Protected, ISO 8846

### WARRANTY

3 Year Limited Warranty  
See SB-1050 For Full Warranty Details

### SHIPPING

Net Weight (Boxed): 2.5 Lb [1.1 Kg] each  
Carton Weight: 27 Lb [12.2 Kg]  
Pumps in carton: 10  
Carton Size: 24"L x 18"W x 11"H [60 cm x 45 cm x 28 cm]

### RELATED DOCUMENTS

Catalog: MS-030-083 / 030-084  
Installation Manual: 911-467  
Maintenance: 911-467  
Applications Spec Guide: MS-020-005  
Warranty: SB-1041 / SB-1050

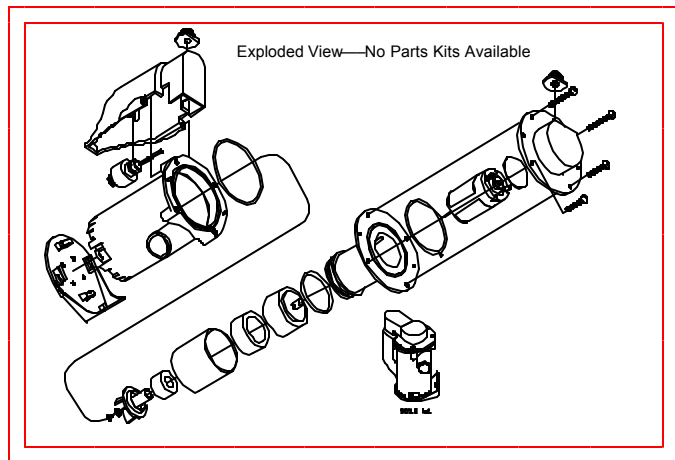

# MARINE PRODUCT DATA SHEET

OEM 1700-100-010 (500 GPH)  
 AFTERMARKET 1700-101-010 (500 GPH)



## TYPICAL PERFORMANCE @ 12V DC

PRESSURE		FLOW		CURRENT
METERS	FT OF HEAD	GPH	LPH	AMPS
0.0	0	500	1892	1.4
0.9	3	289	1093	1.3
1.5	5	0	0	1.1

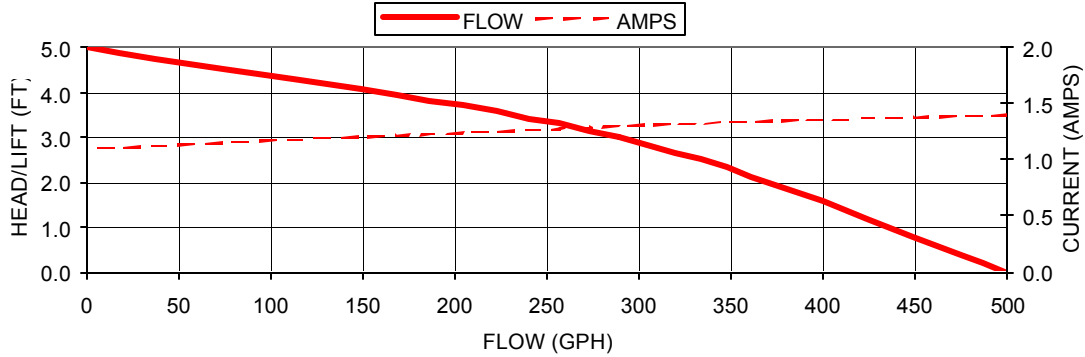

## DIMENSIONS [mm]

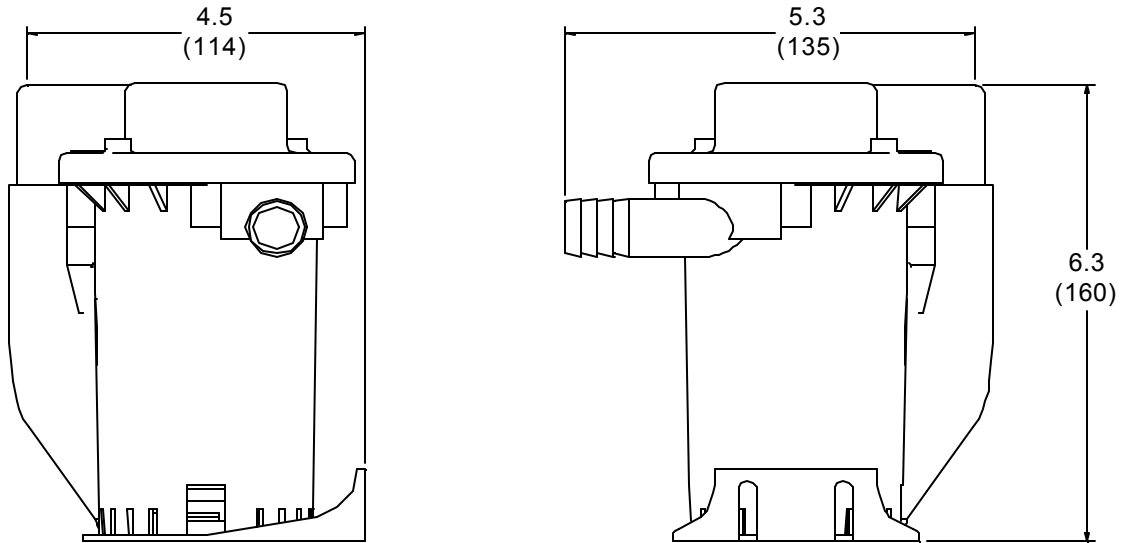

\*ISO Registered Facility

SHURflo reserves the right to update specifications, prices, or make substitutions.

SHURflo \*  
 5900A Katella Ave.  
 Cypress, Ca. 90630  
 (800) 854-3218 (562) 795-5200  
 FAX (562) 795-7554  
 Shipping/UPS: 5900C Katella Ave.  
 Cypress, Ca. 90630

SHURflo East  
 52748 Park Six Court  
 Elkhart, IN 46514-5427  
 (800) 762-809 (574) 262-0478  
 FAX (574) 264-2169  
 Http://www.shurflo.com  
 © 2001

SHURflo Ltd. \*  
 Unit 5 Sterling Park  
 Gatwick Road, Crawley  
 West Sussex, RH10 2QT  
 United Kingdom  
 +44 1293 424000  
 FAX +44 1293 421880

