



MARINE PRODUCT DATA SHEET

OEM: 357-111-00 (700 GPH)
AFTERMARKET: 357-111-10 (700 GPH)

Everything you are looking for in a bilge pump. Our tough, high density nylon housing and heavy duty water cooled motor gives the SHURflo Bilge Pump unparalleled reliability. Installations are a snap with our unique swivel baseplate and extended 6' tinned wire and assembly. Easy installation and removable cartridge for easy cleaning.

TYPICAL APPLICATIONS

12V Marine Bilge Water Evacuation. For other applications, Contact SHURflo.

PUMP

Type: Centrifugal Pump
Port: 3/4" Barb
Liquid: 130 °F [54 °C] Max
Prime: Flooded Inlet
Run Dry: No

ELECTRICAL

Motor: 12VDC Permanent Magnet, Continuous Duty
Protection: External Fuse
Leads: 6 ft (1.8M) Tinned, 16 AWG
Fuse: 5 Amp Recommended
Control: No Control

MATERIALS

Housing: High Strength Nylon
Impeller: High Strength Nylon
Hardware: Stainless Steel

APPROVALS

Ignition Protected, CE, ISO 8846

WARRANTY

3 Year Limited Warranty
See SB-1050 For Full Warranty Details

SHIPPING

Net Weight (Boxed): 1.25 Lb (0.56 Kg) each
Carton Weight: 30 Lb [13.6 Kg]
Pumps in Carton: 24
Carton Size: 24"L x 18"W x 11" H [61 cm x 46 cm x 28 cm]

RELATED DOCUMENTS

Catalog: MS-030-140
Installation Manual: 911-593-00
Maintenance: 911-593-00
Applications Spec Guide: MS-020-005
Warranty: SB-1050

Replacement Kits

94-006-00



94-007-00



PERFORMANCE @ 13.6V DC

PRESSURE		FLOW		CURRENT
METERS	FT OF HEAD	GPH	LPH	AMPS
0.0	0	726	2747	3.90
1.20	4	631	2388	3.86
2.40	8	458	1733	3.70

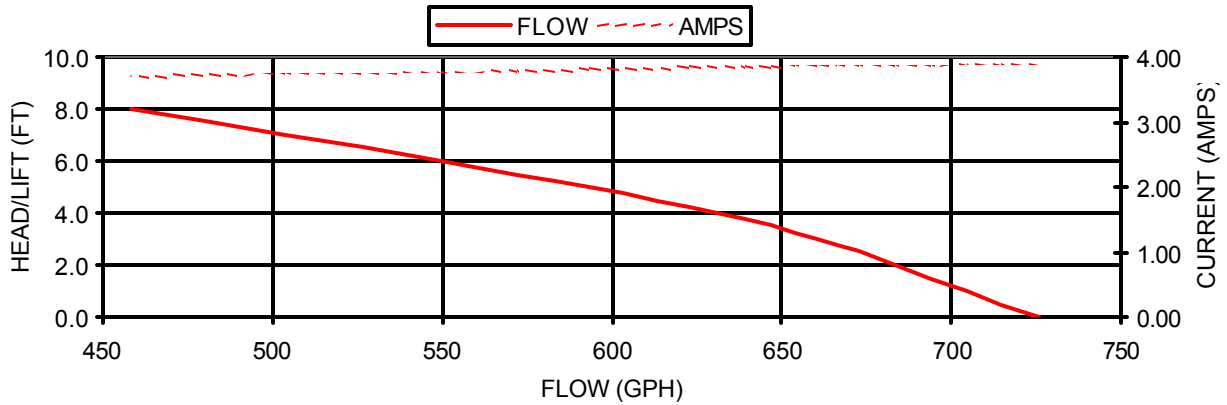

DIMENSIONS [mm]

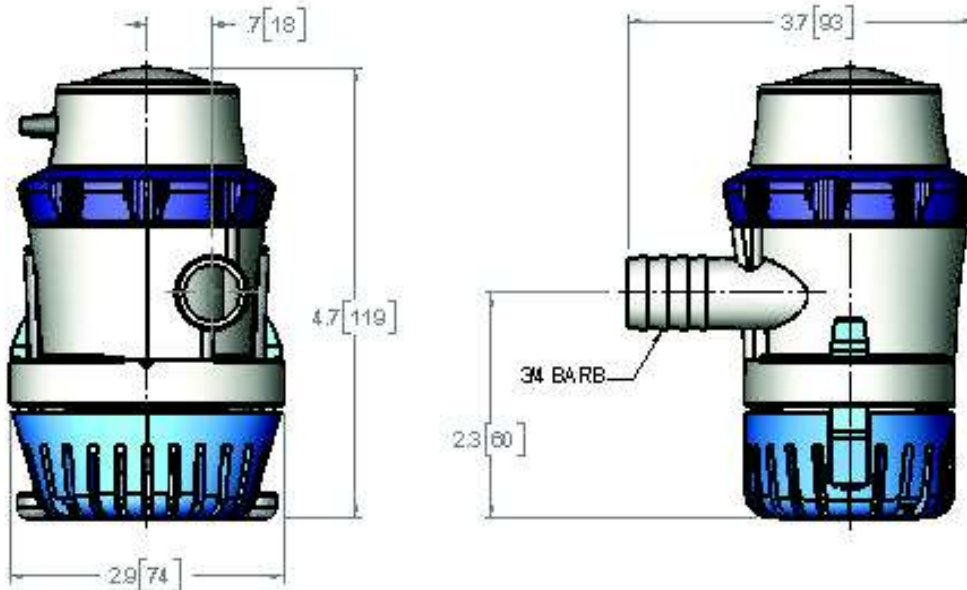

*ISO Registered Facility

SHURflo reserves the right to update specifications, prices, or make substitutions.



SHURflo *
5900A Katella Ave.
Cypress, Ca. 90630
(800) 854-3218 (562) 795-5200
FAX (562) 795-7554
Shipping/UPS: 5900C Katella Ave.
Cypress, Ca. 90630

SHURflo East
52748 Park Six Court
Elkhart, IN 46514-5427
(800) 762-809 (574) 262-0478
FAX (574) 264-2169
Http://www.shurflo.com
© 2001

SHURflo Ltd. *
Unit 5 Sterling Park
Gatwick Road, Crawley
West Sussex, RH10 2QT
United Kingdom
+44 1293 424000
FAX +44 1293 421880